

SolidWorks® Tutorial 12

CLAMP

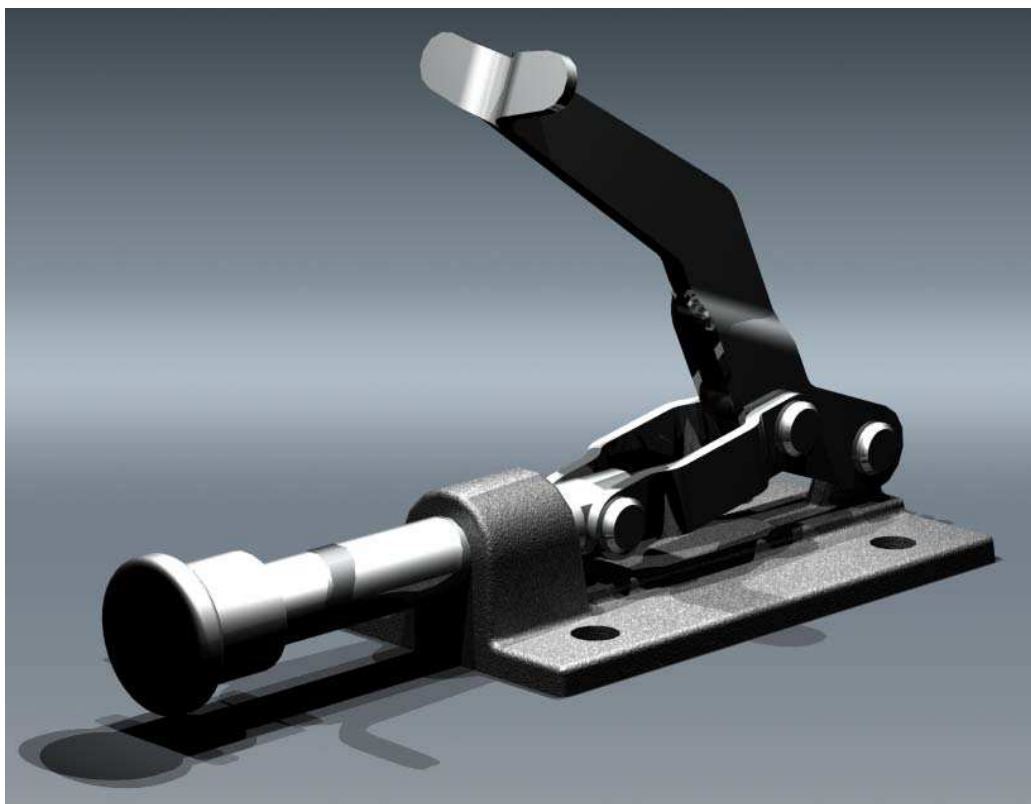

Preparatory Vocational Training
and Advanced Vocational Training



© 1995-2009, Dassault Systèmes SolidWorks Corp.
300 Baker Avenue
Concord, Massachusetts 01742 USA
All Rights Reserved.

U.S. Patents 5,815,154; 6,219,049; 6,219,055

Dassault Systèmes SolidWorks Corp. is a Dassault Systèmes S.A. (Nasdaq:DASTY) company.

The information and the software discussed in this document are subject to change without notice and should not be considered commitments by Dassault Systèmes SolidWorks Corp.

No material may be reproduced or transmitted in any form or by any means, electronic or mechanical, for any purpose without the explicit written permission of Dassault Systèmes SolidWorks Corp.

The software discussed in this document is furnished under a license and may be used or copied only in accordance with the terms of this license. All warranties given by Dassault Systèmes SolidWorks Corp. as to the software and documentation are set forth in the Dassault Systèmes SolidWorks Corp. License and Subscription Service Agreement, and nothing stated in, or implied by, this document or its contents shall be considered or deemed a modification or amendment of such warranties.

SolidWorks® is a registered trademark of Dassault Systèmes SolidWorks Corp.

SolidWorks 2009 is a product name of Dassault Systèmes SolidWorks Corp.

FeatureManager® is a jointly owned registered trademark of Dassault Systèmes SolidWorks Corp.

Feature Palette™ and PhotoWorks™ are trademarks of Dassault Systèmes SolidWorks Corp.

ACIS® is a registered trademark of Spatial Corporation.

FeatureWorks® is a registered trademark of Geometric Software Solutions Co. Limited.

GLOBEtrotter® and FLEXIm® are registered trademarks of Globetrotter Software, Inc.

Other brand or product names are trademarks or registered trademarks of their respective holders.

SolidWorks Benelux developed this tutorial for self-training with the SolidWorks 3D CAD program. **Any other use of this tutorial or parts of it is prohibited.** For questions, please contact SolidWorks Benelux. Contact information is printed on the last page of this tutorial.

Initiative: Kees Kloosterboer (SolidWorks Benelux)

Educational Advisor: Jack van den Broek (Vakcollege Dr. Knippenberg)

Realization: Arnoud Breedveld (PAZ Computerworks)

COMMERCIAL COMPUTER SOFTWARE - PROPRIETARY

U.S. Government Restricted Rights. Use, duplication, or disclosure by the government is subject to restrictions as set forth in FAR 52.227-19 (Commercial Computer Software - Restricted Rights), DFARS 227.7202 (Commercial Computer Software and Commercial Computer Software Documentation), and in the license agreement, as applicable.

Contractor/Manufacturer:

Dassault Systèmes SolidWorks Corp., 300 Baker Avenue,
Concord, Massachusetts 01742 USA

Portions of this software are copyrighted by and are the property of Electronic Data Systems Corporation or its subsidiaries, Copyright© 2009

Portions of this software © 1999, 2002-2009 ComponentOne

Portions of this software © 1990-2009 D-Cubed Limited.

Portions of this product are distributed under license from DC Micro Development, Copyright © 1994-2009 DC Micro Development, Inc. All Rights Reserved.

Portions © eHelp Corporation. All Rights Reserved.

Portions of this software © 1998-2009 Geometric Software Solutions Co. Limited.

Portions of this software © 1986-2009 mental images GmbH & Co. KG

Portions of this software © 1996-2009 Microsoft Corporation. All Rights Reserved.

Portions of this software © 2009, SIMULOG.

Portions of this software © 1995-2009 Spatial Corporation.

Portions of this software © 2009, Structural Research & Analysis Corp.

Portions of this software © 1997-2009 Tech Soft America.

Portions of this software © 1999-2009 Viewpoint Corporation.

Portions of this software © 1994-2009, Visual Kinematics, Inc.

All Rights Reserved.

Clamp

In this tutorial we are going to make a clamp. Many of the topics we will use you have seen already, but we are also going to show you some new tools, including:

- Movements in an **assembly**.
- The creation of a **rendering** with PhotoWorks.

First, we are going to mold the parts, and then we will make the **assembly**, in which you can see the exact movements of the product. Finally, we are going to make a **rendering** in PhotoWorks.

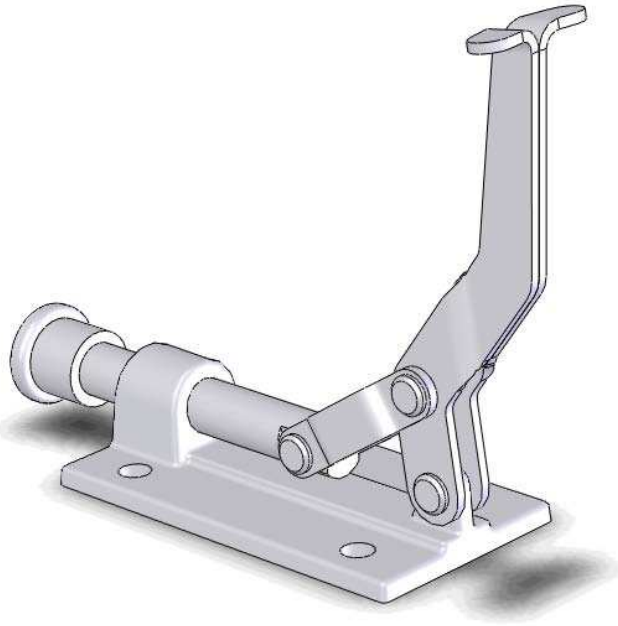

Work plan

The first part we are going to make is the base. In the illustration below you can see the dimensions.

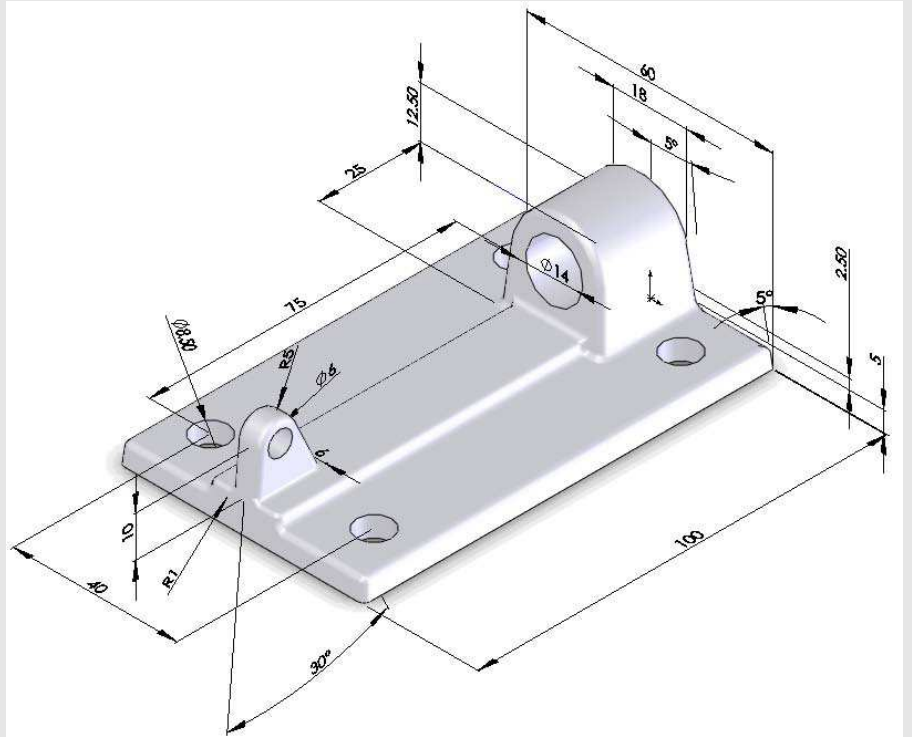

First, you will make a work plan. How would you build this part?

The main problem in this part is that almost all the vertical planes are at an angle of 5°, which is often the case with castings. To achieve that angle in the model, we use a new feature: **Draft**.

Make a plan by yourself for how to create this model.

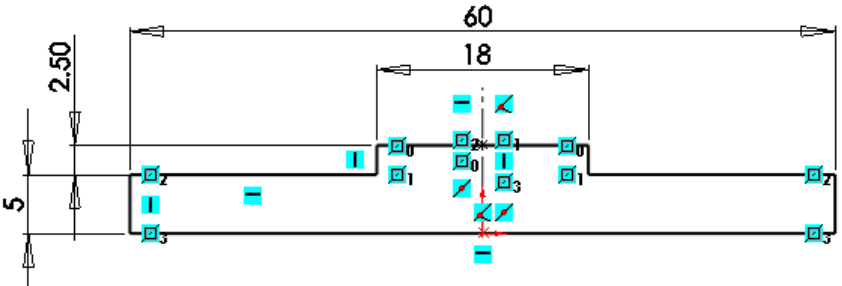
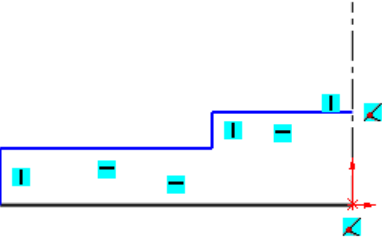
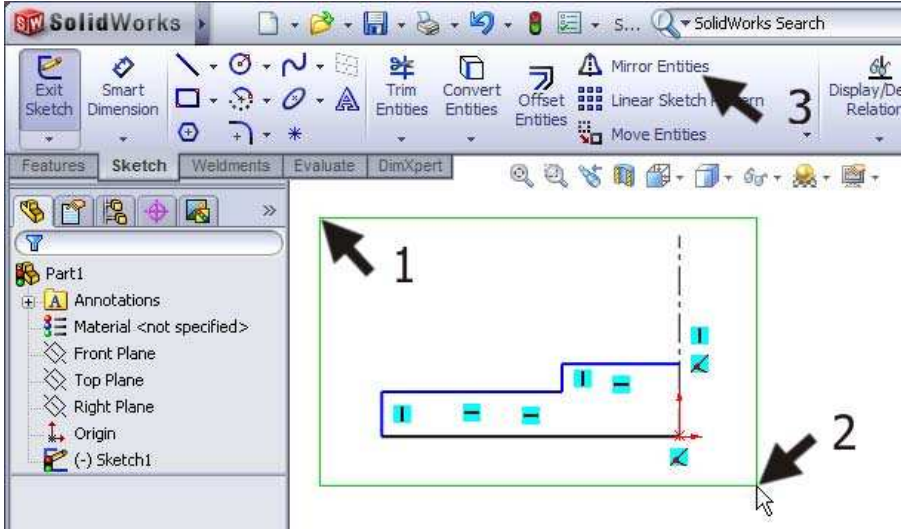
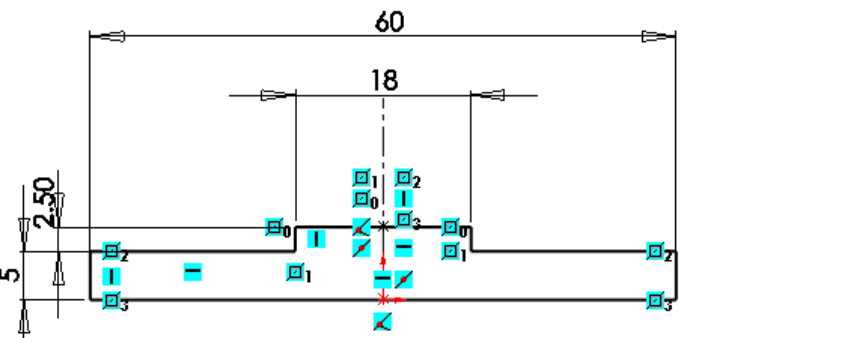
1	Start SolidWorks and open a new part.	
2	<p>Select the Front Plane and make a sketch like you see in the illustration on the right.</p> <p>Can you build this sketch by yourself? Fine! After that continue to Step 6.</p> <p>If you cannot build this sketch, then follow the next steps.</p>	
3	Draw the lines as shown on the right. Note the position of the origin .	
4	<p>Now, select the whole sketch (all lines and the centerline). The easiest way to do this is by dragging a frame around the whole sketch.</p> <p>Next, click on 'Mirror Entities' in the CommandManager.</p>	
5	Set the dimensions in the sketch as shown on the right.	

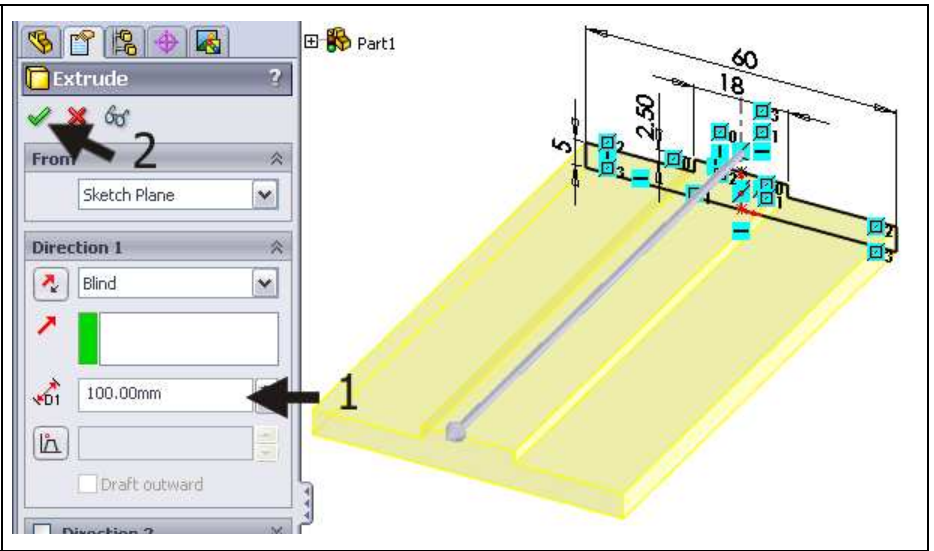
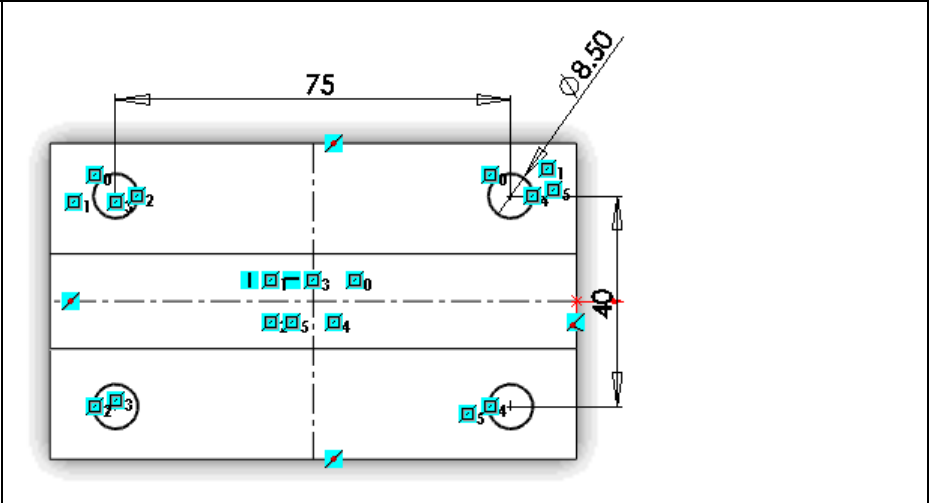
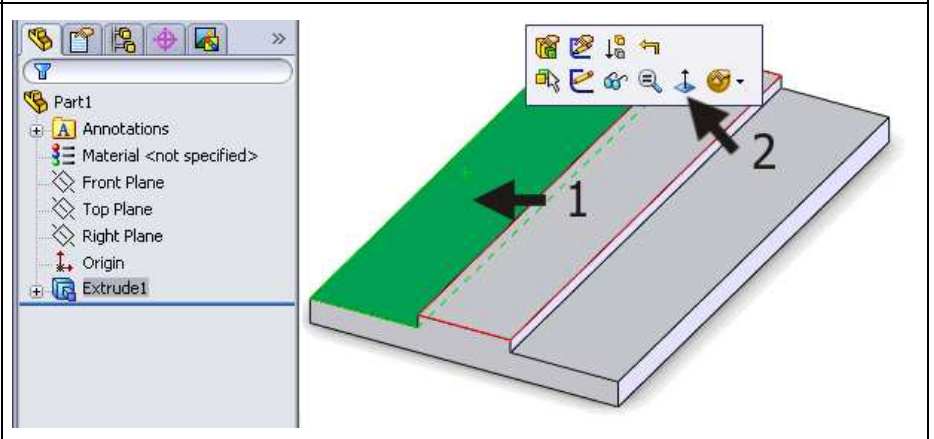

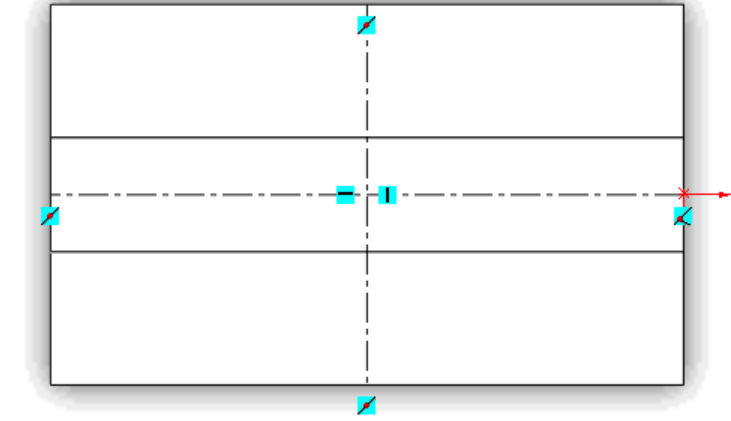
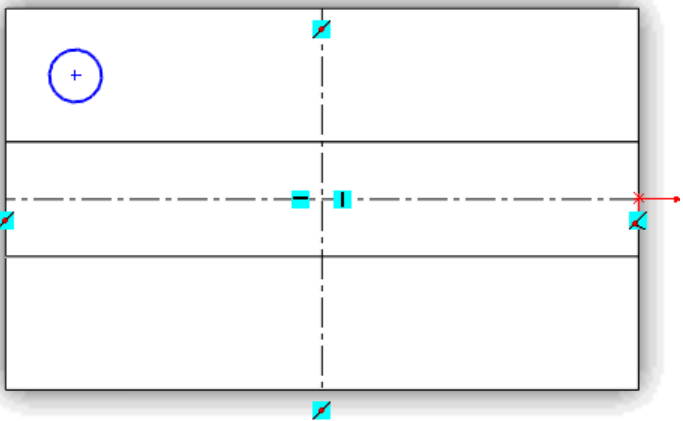
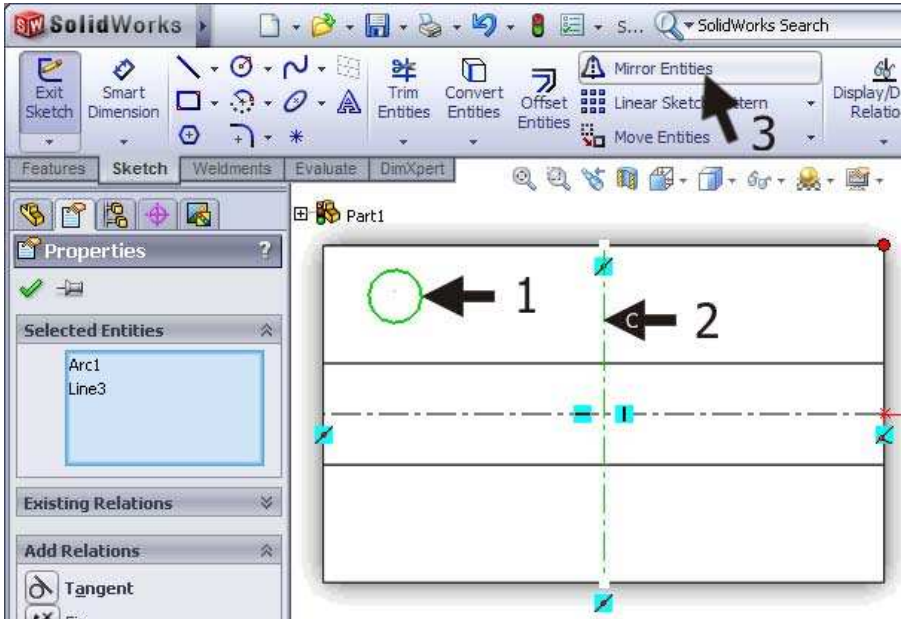
<p>6</p>	<p>Extrude the sketch over a length of '100mm'.</p>	
<p>7</p>	<p>We are now going to make the mounting holes. Create a sketch on the upper surface of the model as shown in the illustration on the right.</p> <p>Can you build this sketch by yourself? Great! Continue to Step 14.</p> <p>If you cannot build this sketch, than follow the next few steps.</p>	
<p>8</p>	<ol style="list-style-type: none"> 1. First, select the plane where you want to make the sketch. 2. Click on Normal To in the menu that appears. 	

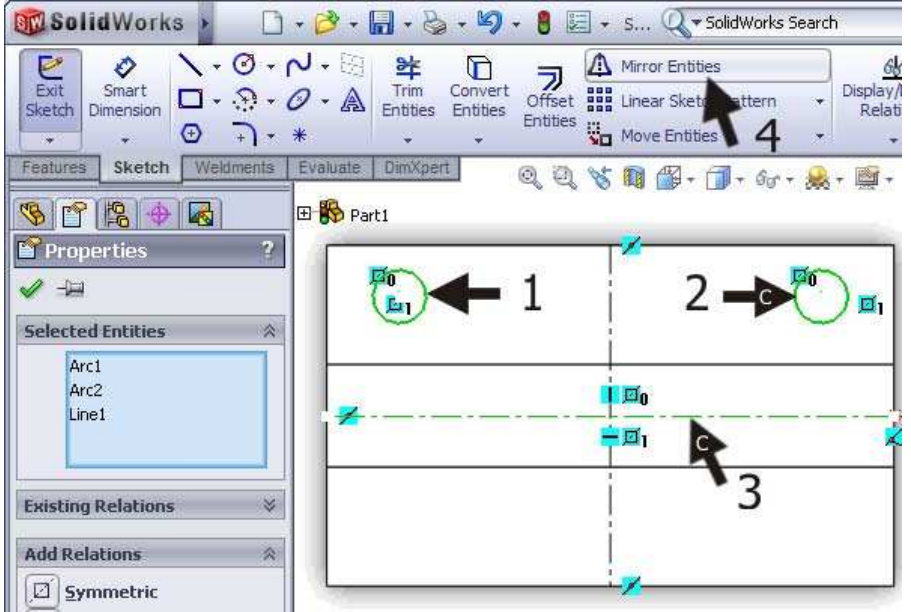
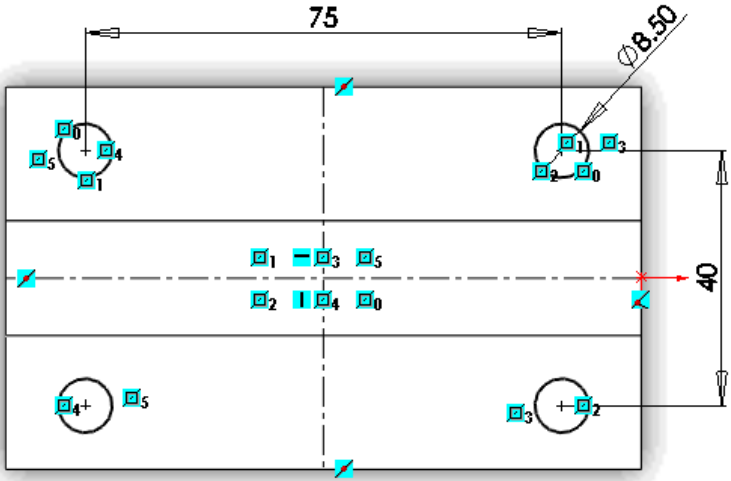
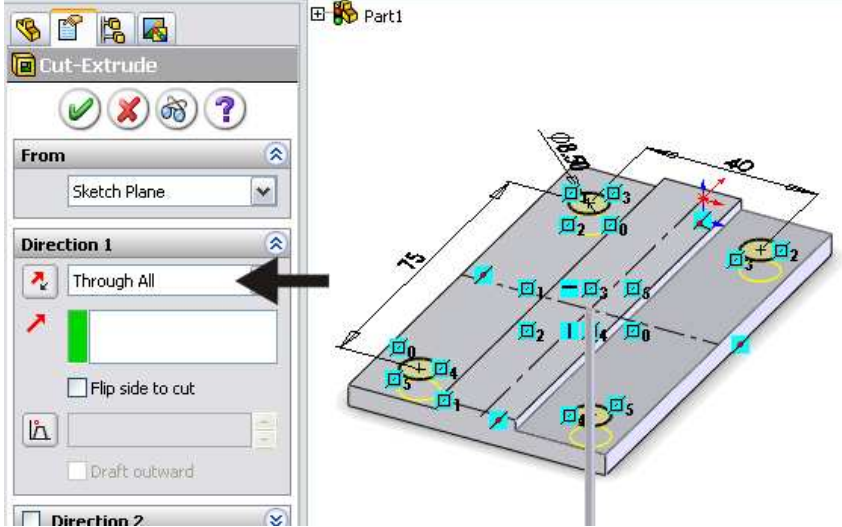

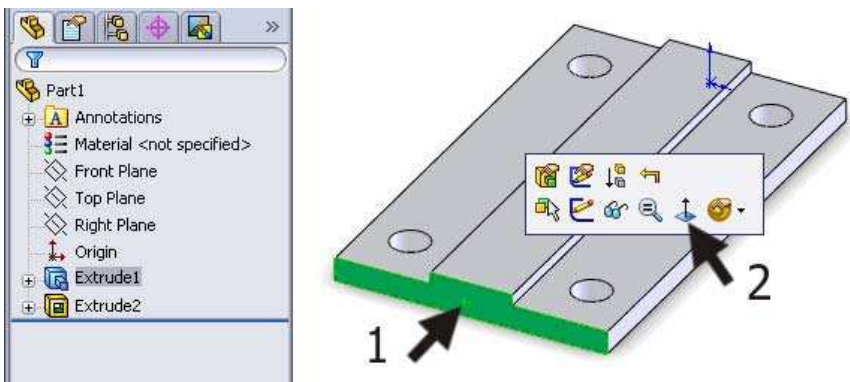
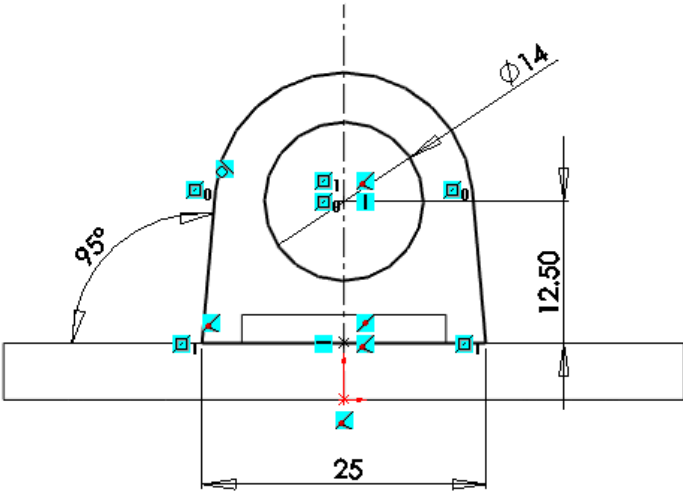
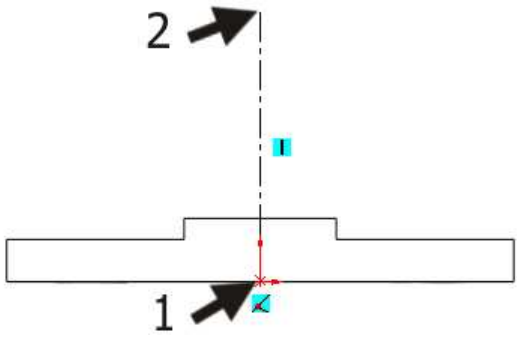
<p>9</p> <p>Next, draw the two centerlines, as illustrated on the right.</p> <p>Be careful to draw the centerlines in the exact center of the model. To see if this really works out properly, you can verify it with the Midpoint symbols, which you can find at the end of the centerlines.</p>	
<p>10</p> <p>Draw a circle, similar to the illustration on the right.</p>	
<p>11</p> <p>Now mirror the circle:</p> <ol style="list-style-type: none"> 1. Select the circle. 2. Hold the <Ctrl> key and select the vertical centerline. 3. Select 'Mirror Entities' in the CommandManager. 	

<p>12</p> <p>The two circles we have created will be mirrored a second time:</p> <p>1-3 Select the two circles we have already drawn before and the horizontal centerline. Use the <Ctrl> key.</p> <p>4. Select 'Mirror Entities' in the CommandManager.</p>	
<p>13</p> <p>Add the dimensions as shown to the sketch.</p>	
<p>14</p> <p>Make an Extruded Cut from the sketch with depth 'Through All'.</p>	
<p>Hint!</p>	<p>In these two sketches we have mirrored some parts. This not only saves</p>

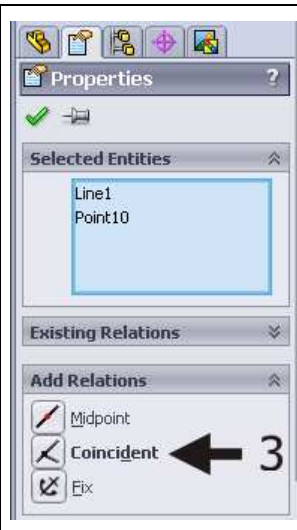
		time because you have to draw less, but the mirrored parts also remain constrained to each other and will always be symmetrical.
<p>15</p>	<p>Now, select the front plane from the model and select Normal To.</p> <p>Make a sketch on this plane.</p>	
<p>16</p>	<p>Can you build this sketch all by yourself? Great! Continue at Step 25.</p> <p>If you cannot build this sketch, then follow the next steps.</p>	
<p>17</p>	<p>First, draw a centerline from the origin vertically upwards. The exact length does not matter.</p>	

<p>18</p> <p>Draw a horizontal line as illustrated on the right.</p> <p>The beginning of the line is at the upper surface of the model.</p> <p>The endpoint is on the vertical centerline.</p> <p>Push the <Esc> key to abort the line command.</p>		
<p>19</p> <p>Now, draw a second line as shown.</p> <p>The beginning of the line is exactly on the beginning of the last line you drew.</p> <p>The line is not positioned vertically but at a slight angle in relation to the vertical centerline.</p>		
<p>20</p> <ol style="list-style-type: none"> 1. Click on Arc in the CommandManager. 2. Click on Tangent Arc in the PropertyManager. 3. Click on the endpoint of the line you have just drawn to get the first point of the arc. 4. To get the endpoint of the arc, click on the centerline as shown. 5. Click the <Esc> key to abort the command. 		

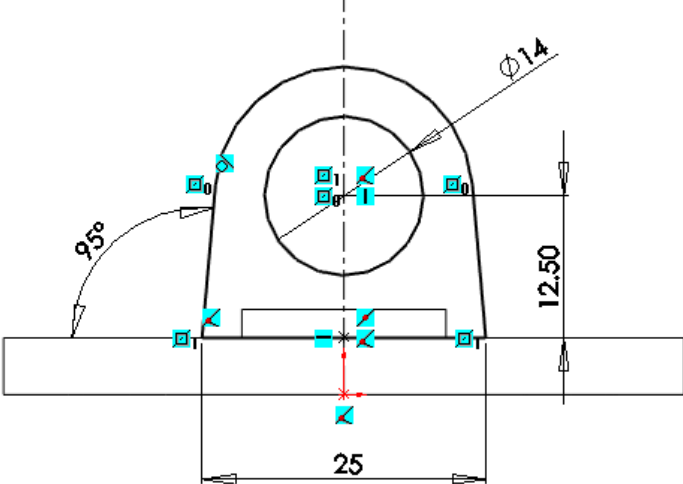
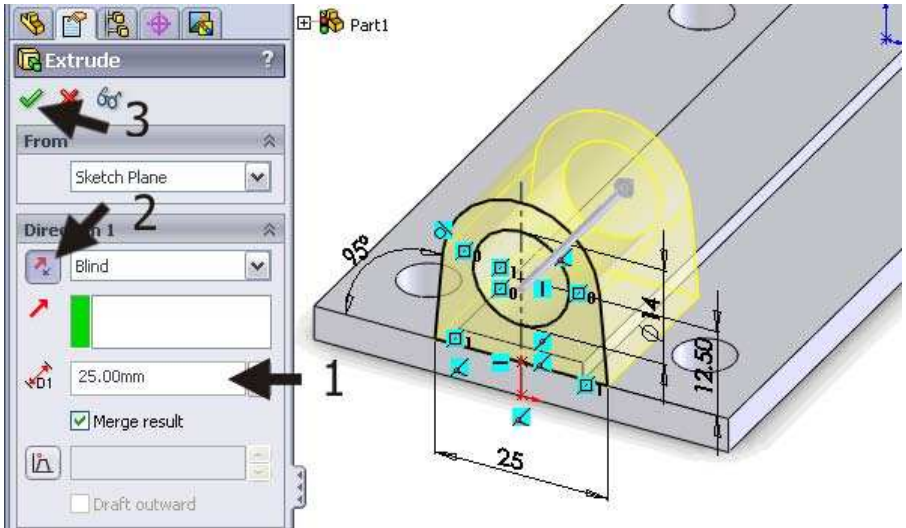
<p>21</p> <ol style="list-style-type: none"> 1. Select the centerline. 2. Hold the <Ctrl> key and select the center of the arc. This is marked in the sketch as a little 'x'. 3. Click on 'Coincident' in the PropertyManager. 	 <p>The screenshot shows the PropertyManager window with 'Selected Entities' containing 'Line1' and 'Point10'. Under 'Add Relations', the 'Coincident' option is highlighted with an arrow labeled '3'. In the background sketch, a vertical centerline is selected with arrow '1' and the center of an arc is selected with arrow '2'.</p>
<p>22</p> <p>Select the whole sketch (including the centerline), and click on 'Mirror Entities' in the CommandManager.</p>	 <p>The screenshot shows the CommandManager with 'Mirror Entities' selected, indicated by arrow '3'. In the sketch, the entire sketch area is enclosed in a green selection box, with arrow '1' pointing to the box and arrow '2' pointing to the bottom edge of the box.</p>
<p>23</p> <p>Next, you have to draw a circle.</p> <p>Put the center of the circle on the center of the arc.</p>	 <p>The screenshot shows the 'Circle' tool selected in the CommandManager (arrow '1'). The sketch shows a circle drawn with its center on the arc's center (arrow '2'). A dimension of 3.25 is shown for the circle's radius (arrow '3').</p>

<p>24</p>	<p>Set the dimensions in the sketch as shown.</p>	
<p>25</p>	<p>Extrude this sketch.</p> <ol style="list-style-type: none"> 1. Set the depth to '25mm'. 2. Make sure your extrusion extends in the right direction with Reverse Direction. Rotate the model to its isometric position. Otherwise, you will not be able to see this! 3. Click on OK. 	
<p>26</p>	<p>We are going to set all vertical planes at an angle of 5°. For this we use a new feature: Draft.</p> <p>Click on 'Draft' in the CommandManager.</p>	

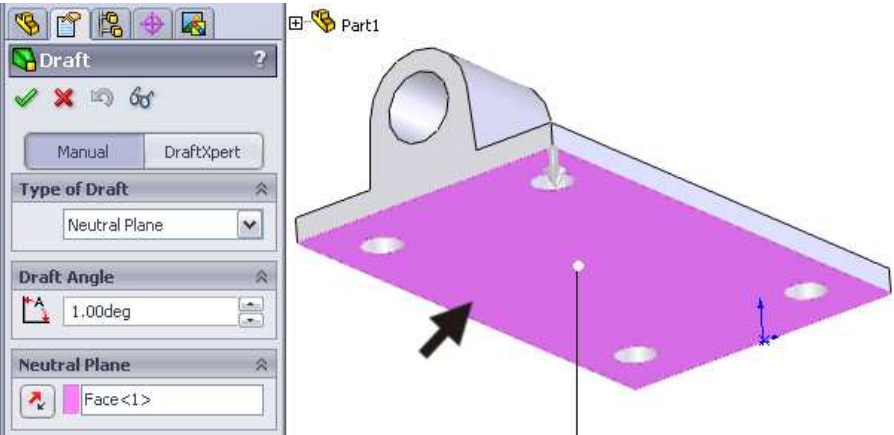
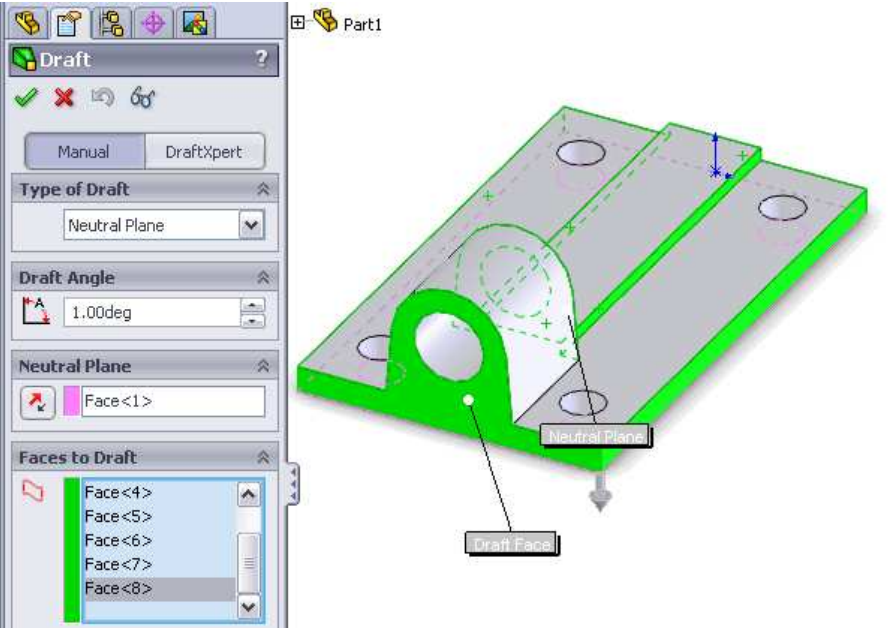
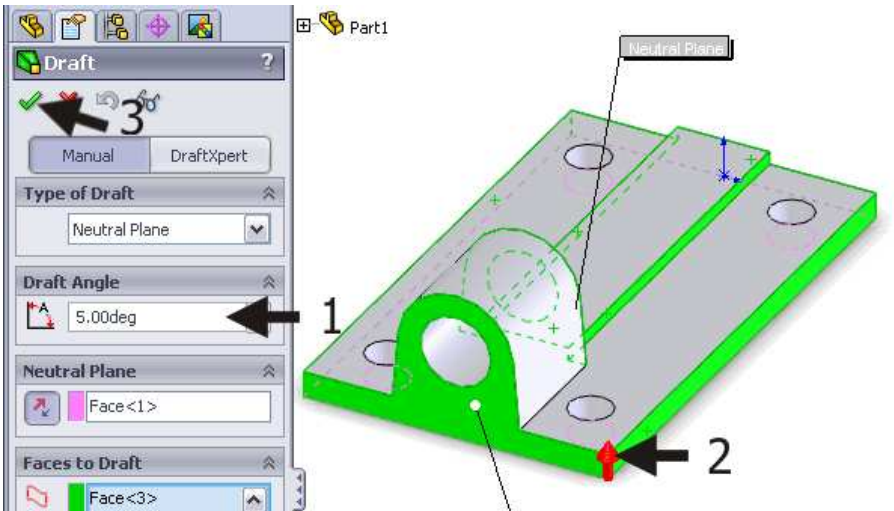
<p>27</p> <p>First, we select the 'Neutral Plane'. This is the partitioning plane from the mold or matrix.</p> <p>Rotate the model so you have a good view of the bottom.</p> <p>Select the bottom plane.</p>		 <p>The screenshot shows the Draft tool interface. The 'Type of Draft' is set to 'Neutral Plane'. The 'Draft Angle' is set to 1.00deg. The 'Neutral Plane' is set to 'Face<1>'. The 3D model shows a purple highlighted bottom surface of a clamp part.</p>
<p>28</p> <p>We can now select the planes that we want to tilt.</p> <p>Click on all vertical planes as shown in the illustration on the right. There are 7 planes in total. To select them all, you will have to rotate the model every now and then.</p>		 <p>The screenshot shows the Draft tool interface. The 'Type of Draft' is 'Neutral Plane' and the 'Draft Angle' is 1.00deg. The 'Neutral Plane' is 'Face<1>'. The 'Faces to Draft' list includes Face<4>, Face<5>, Face<6>, Face<7>, and Face<8>. The 3D model shows several vertical faces highlighted in green.</p>
<p>29</p> <p>Next, you have to set two more items.</p> <ol style="list-style-type: none"> 1. Set the 'Draft Angle' to '5°' in the PropertyManager. 2. In the model the angle direction is indicated by an arrow. Make sure this arrow points upward. You can change direction by clicking on the arrow. 3. Click on OK in the PropertyManager. 		 <p>The screenshot shows the Draft tool interface. The 'Type of Draft' is 'Neutral Plane' and the 'Draft Angle' is now 5.00deg. The 'Neutral Plane' is 'Face<1>'. The 'Faces to Draft' list includes Face<3>. The 3D model shows a red arrow pointing upwards from the draft angle field, indicating the direction of the draft angle.</p>

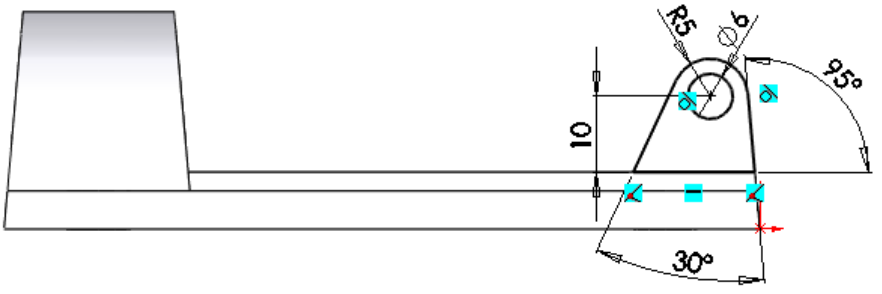
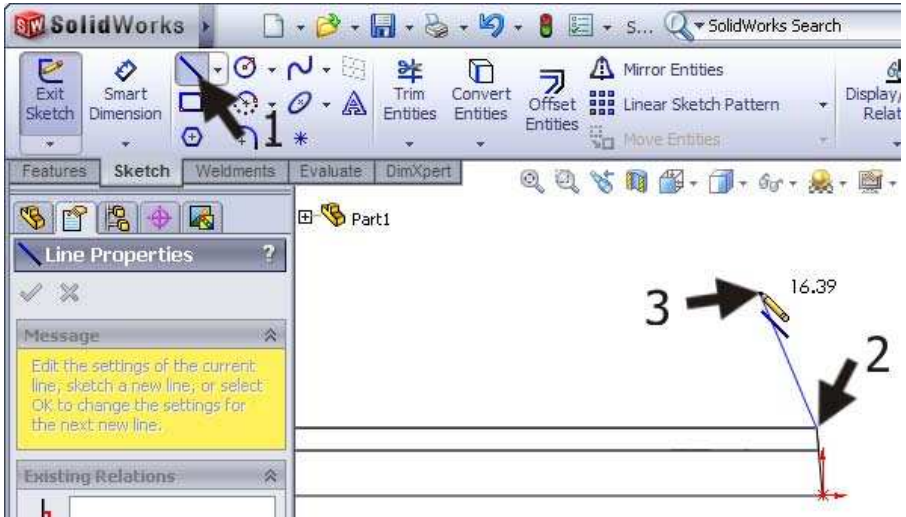
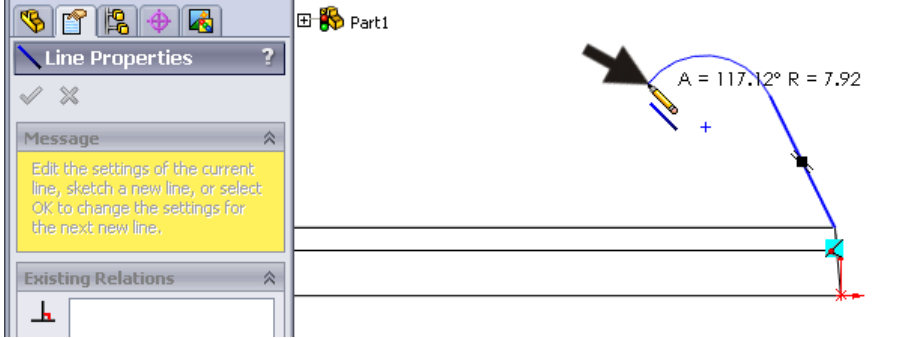
<p>30</p>	<p>Select the right plane in the model and make the sketch as shown.</p> <p>If you can do it yourself, then continue to Step 37, if not, follow the few next steps.</p>	
<p>31</p>	<p>Draw a line similar to the one in the illustration.</p>	
<p>32</p>	<p>Use the Autotransitioning technique that we used before when we wanted to draw a part of a circle using the line command.</p> <ol style="list-style-type: none"> 1. Move the cursor away from the last point that you drew. 2. Replace the cursor exactly to the last point again (do NOT click on it!) 3. Move the cursor away and you will be drawing an arc. 4. Click as shown in the illustration to set an arc. 	

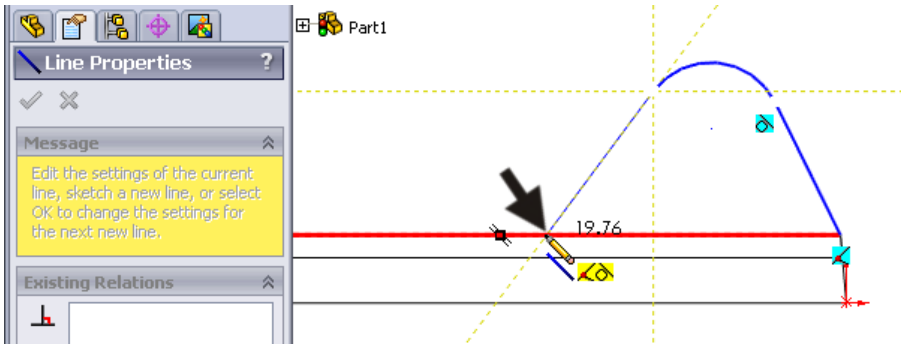
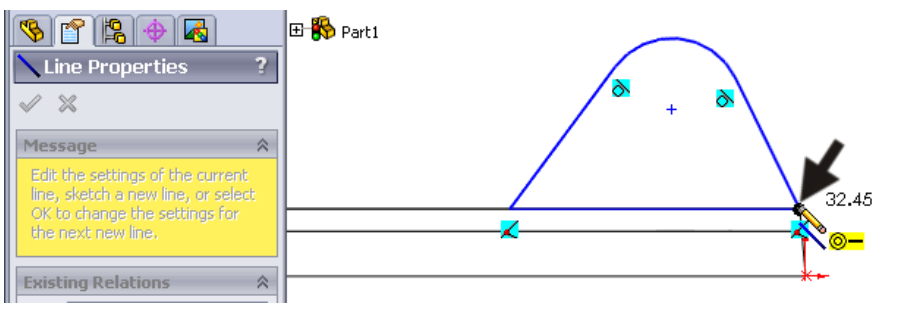
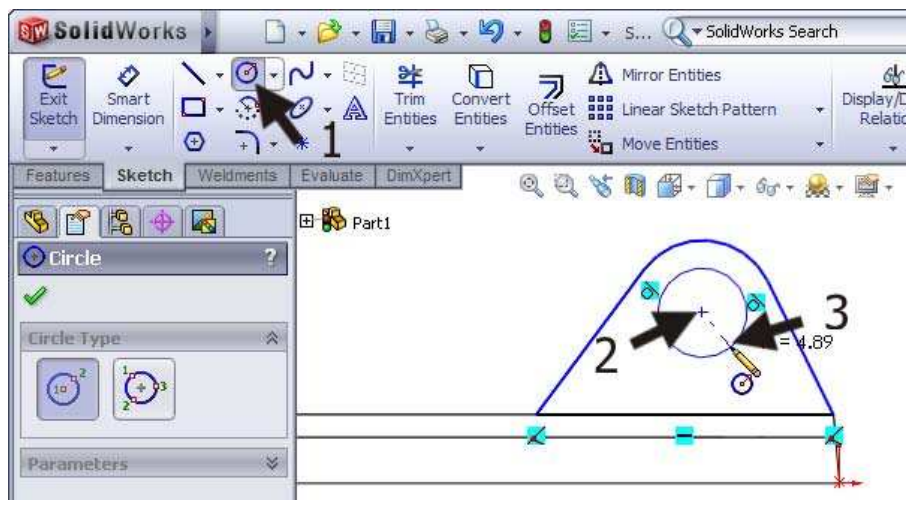
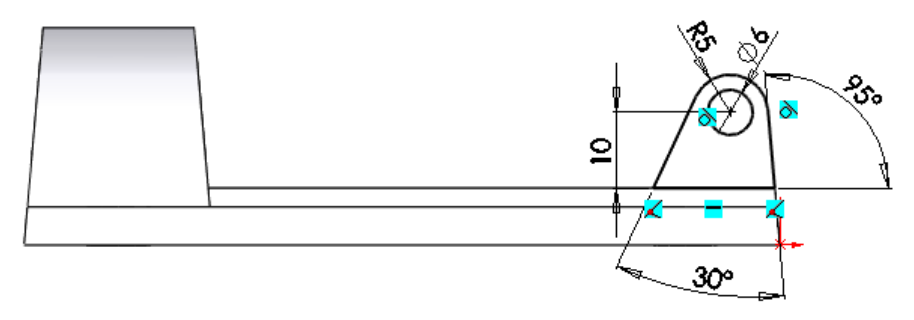
<p>33</p>	<p>Click on the spot as shown on the right.</p> <p>Use the dotted auxiliary line: it is aligned to the circle.</p> <p>Note the two yellow icons near the cursor. These must be visible at the moment that you set the end-point.</p>	
<p>34</p>	<p>Click on the beginning of the first line now.</p>	
<p>35</p>	<p>Draw a circle with its mid-point on the midpoint of the arc.</p>	
<p>36</p>	<p>Set the dimensions as shown on the right.</p>	

<p>37 Extrude this sketch.</p> <ol style="list-style-type: none"> 1. Select the option 'Mid Plane' in the Property-Manager. 2. Set the distance to '6mm'. 3. Click on OK. 	
<p>38 Round the corners from the model with the 'Fillet' feature.</p> <p>Set the radius to '1.5mm' and select the edges as shown on the right.</p> <p>Click on OK.</p>	
<p>39 Use the 'Fillet' feature again to round off the rest of the edges. Do this using a radius of '1mm'.</p>	
<p>40 The first part of the clamp</p>	

is now ready.

Save it as: base.SLDPRT.

Work plan

The next part we will create is half of the arm. This part is made from sheetmetal, so we will be using the SolidWorks **SheetMetal** functions.

To make this part you need to use two new features:

1. **Jog**, which allows you to make a double bend in a part.
2. **Sketched bend**, which allows you to draw a line on a sheet of metal that will act as a bending line.

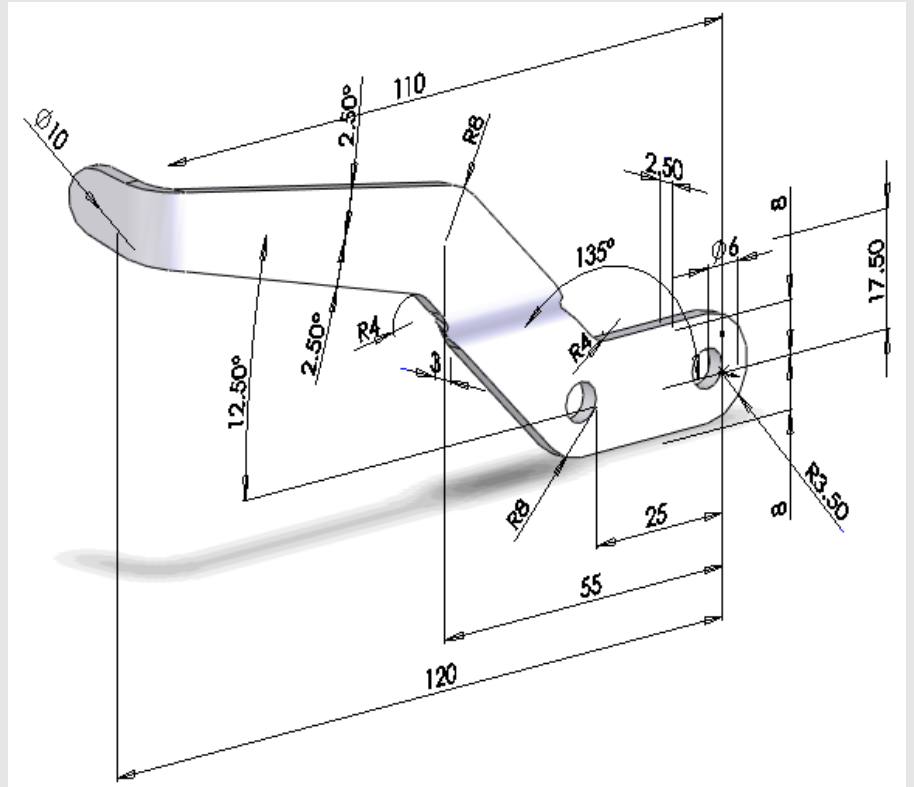

Making this part is actually very simple.

1. Use sheetmetal. While making this part is ease, the sketch we have to make is fairly complicated!
2. Next we will **Jog** the line.
3. Finally, we will bend the sheet with the **Sketched Bend** command.

<p>41 Open a new part.</p> <p>Select the right plane and make the sketch as shown on the right.</p> <p>Did you succeed? Continue with Step 56.</p> <p>If you fail, follow the next few steps.</p>	
<p>42 Draw three centerlines on the right plane first, as shown on the right. Draw the first centerline horizontally from the origin to the left.</p> <p>Set the dimensions as shown in the illustration.</p>	
<p>43</p> <ol style="list-style-type: none"> 1,2 Select the two bottom centerlines (use the <Ctrl> key). 3. Click on 'Offset Entities' in the CommandManager. 4. Set the distance to '8 mm' in the Property-Manager. 5. Check the option 'Bi-directional'. 6. Click on OK. 	

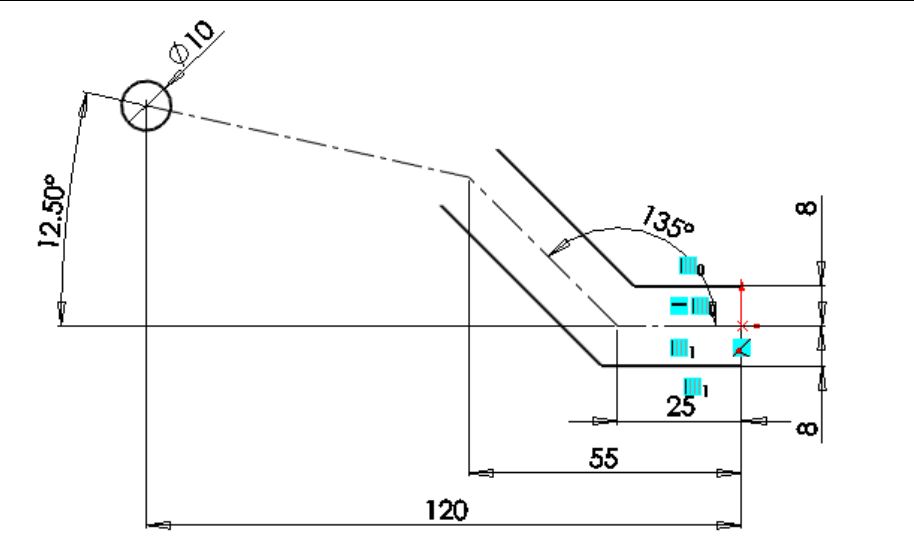
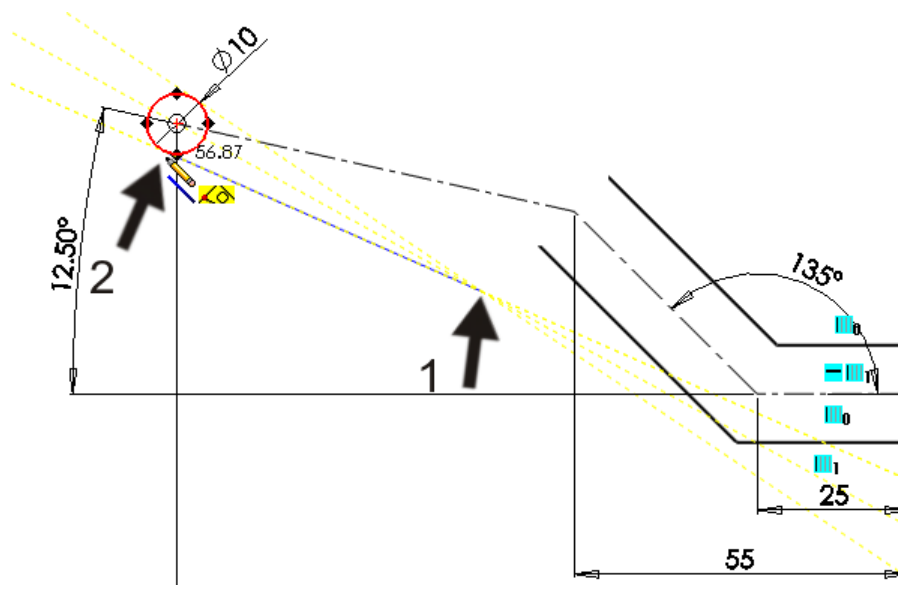
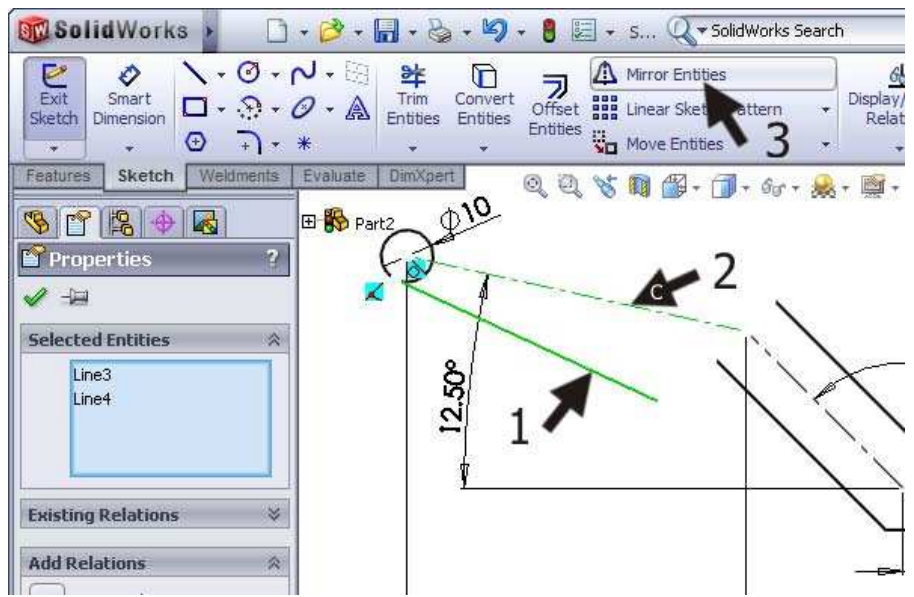
<p>44</p>	<p>Draw a circle with the mid-point on the left end of the centerline. Set the dimension to 'Ø10mm'.</p>	
<p>45</p>	<p>Next, draw a line.</p> <ol style="list-style-type: none"> 1. Set the beginning at random, as shown on the right. 2. Set the second point on the circle. Make sure it touches the circle at the right spot. You can tell by the little icon that pops up at the cursor. 3. Push the <Esc> key on the keyboard to abort the Line command. 	
<p>46</p>	<ol style="list-style-type: none"> 1,2 Select the line and the centerline as shown on the right. 3. Click on 'Mirror Entities' in the CommandManager. 	

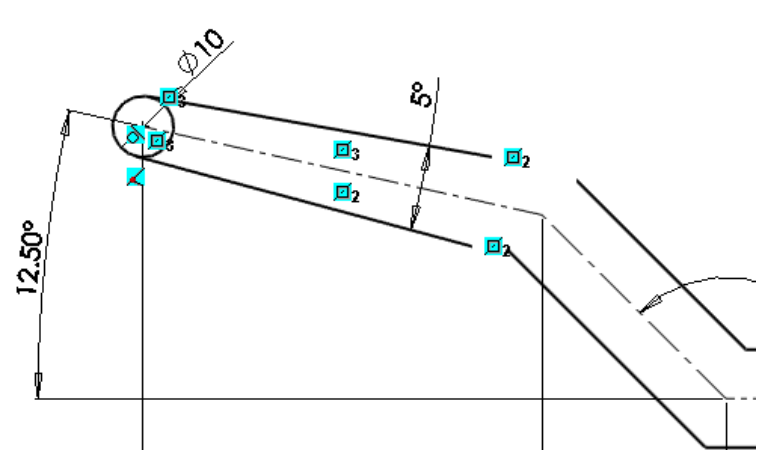
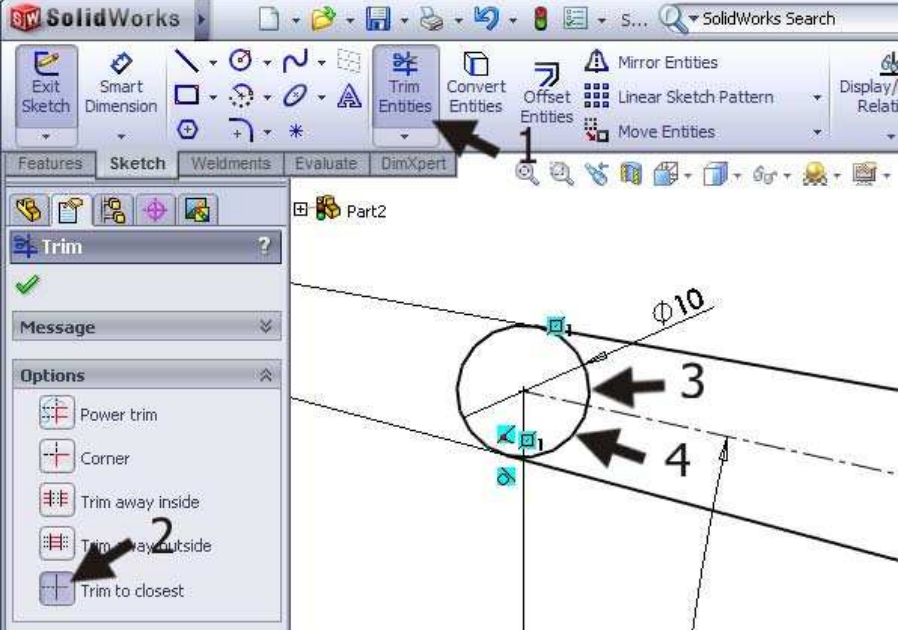
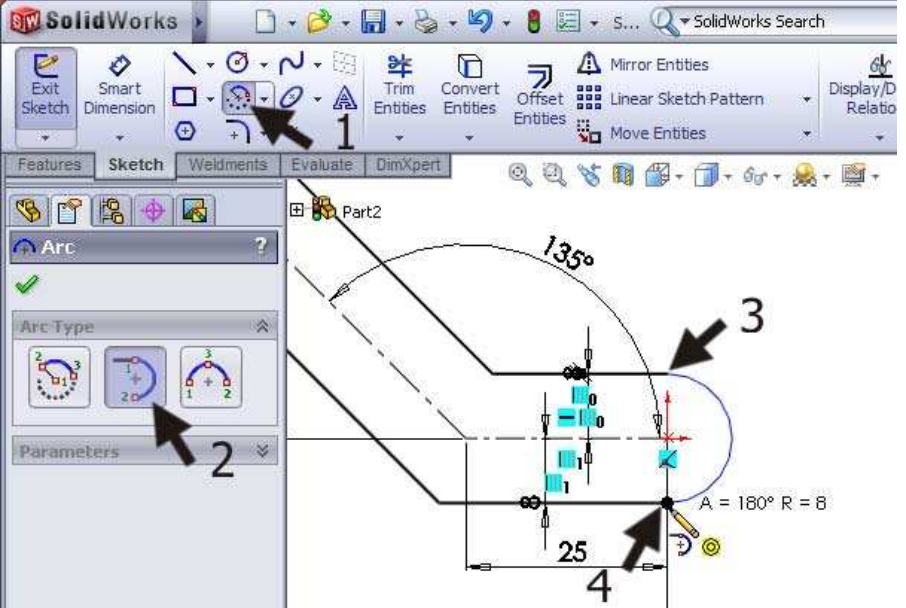
<p>47</p>	<p>Set the angle between the lines to '5°'.</p>	
<p>48</p>	<p>Next, we will trim the part of the circle that lies between the lines.</p> <ol style="list-style-type: none"> 1. Click on 'Trim Entities' in the CommandManager. 2. Click on 'Trim to closest' in the PropertyManager. 3. Click on the parts of the circle that need to be removed. 	
<p>49</p>	<p>We need another half circle at the other end of the sketch.</p> <ol style="list-style-type: none"> 1. Click on Arc in the CommandManager. 2. Click on Tangent Arc in the PropertyManager. 3. Click on the end of the upper line. 4. Click on the end of the bottom line. 	

<p>50</p> <p>We want to round the four corners now.</p> <ol style="list-style-type: none"> 1. Click on Sketch Fillet in the CommandManager. 2. Set the radius to '8mm' in the PropertyManager. 3. Click on the bottom corner as shown. 4,5 Click on both lines which we want to connect with a bended line. 		
<p>51</p> <p>A message appears. Click on 'Yes'.</p>		
	<p>Explanation!</p>	<p>What does the message in Step 51 mean?</p> <p>The upper sloped lines in the sketch are mirrored lines (from Step 46). For this reason, the lines are connected together by a relation: they are symmetrical around the centerline and equally long.</p> <p>When you want to round one of these lines, their lengths will not be equal anymore. The symmetry will be disconnected or destroyed and that is what the software warns you about.</p> <p>The lines were black (fully defined) but after you click on 'Yes' and the symmetry is disconnected, they will turn blue (not fully defined). We will show you how to resolve this later.</p>

<p>52</p>	<p>Set the radius to '4mm' and round the two other corners in the same way.</p>	
<p>53</p>	<p>To return to a fully defined sketch, you have to follow the next few steps:</p> <ol style="list-style-type: none"> 1. Remove the dimension of '5°'. 2. Add two angles of '2.5°' instead. 	
<p>54</p>	<p>Finally, we have to draw two holes.</p> <p>Draw two circles as shown on the right.</p> <p>The midpoints are on the ends of the bottom center-line.</p> <p>Set the size for one of the holes to 'Ø6mm'.</p>	

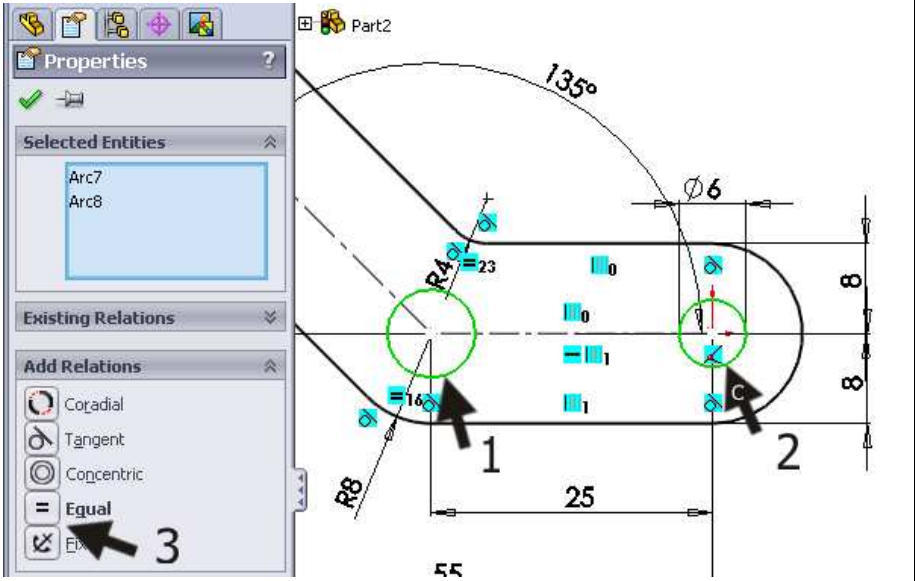
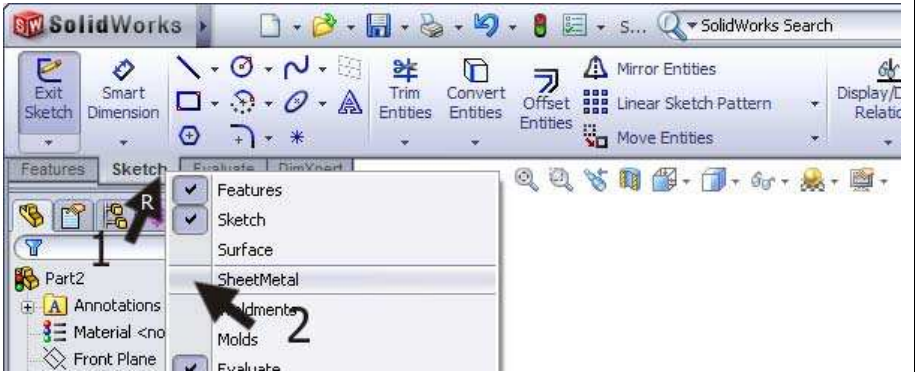
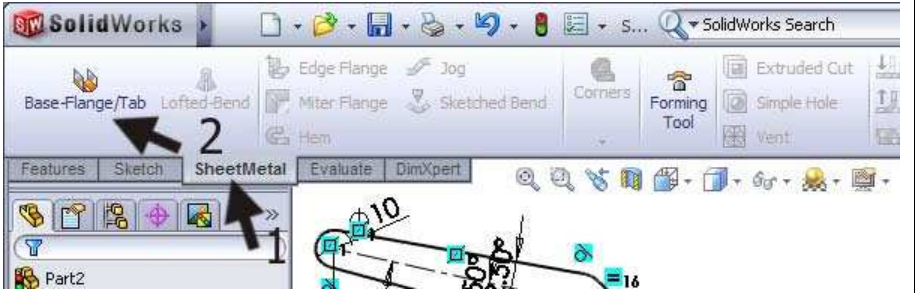
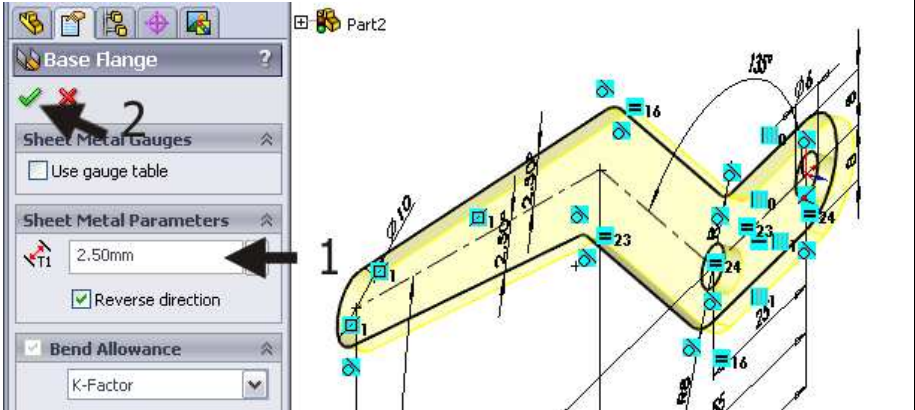
<p>55</p> <ol style="list-style-type: none"> 1. Select both (use the <Ctrl> key). 2. Click on 'Equal' in the PropertyManager. 	 <p>The screenshot shows the SolidWorks PropertyManager for a sketch. The 'Selected Entities' list contains 'Arc7' and 'Arc8'. In the 'Add Relations' section, the 'Equal' relation is highlighted with a black arrow labeled '3'. The sketch itself shows two arcs with radii of 16 and 23, and a 135-degree angle between them. Dimensions of 25, 8, and 6 are also visible.</p>
<p>56</p> <p>We will make a part with sheetmetal from this sketch.</p> <p>Make sure the tab 'Sheet-Metal' is displayed in the CommandManager.</p> <p>If not, right-click on one of the other tabs and select the 'SheetMetal' function in the pop-up menu.</p>	 <p>The screenshot shows the SolidWorks CommandManager. The 'Sketch' tab is active, and a context menu is open over it. The 'SheetMetal' option is highlighted with a black arrow labeled '2'. Other options in the menu include Features, Surface, Addments, Molds, and Evaluate.</p>
<p>57</p> <ol style="list-style-type: none"> 1. Click on 'SheetMetal' in the CommandManager. 2. Click on 'Base-Flange/Tab'. 	 <p>The screenshot shows the SolidWorks CommandManager with the 'SheetMetal' tab selected. The 'Base-Flange/Tab' option is highlighted with a black arrow labeled '1'. Other options in the 'SheetMetal' tab include Lofted-Bend, Miter Flange, Hem, Corners, Forming Tool, and Simple Hole.</p>
<p>58</p> <ol style="list-style-type: none"> 1. Set the thickness for the material to '2.5mm' in the PropertyManager. 2. Click on OK. 	 <p>The screenshot shows the SolidWorks PropertyManager for the 'Base Flange' feature. The 'Sheet Metal Parameters' section is expanded, and the thickness 'T1' is set to '2.50mm', highlighted with a black arrow labeled '1'. The 'Reverse direction' checkbox is checked. The 'Bend Allowance' section is also visible. The sketch in the background shows the resulting 3D model of the clamp with dimensions and a 135-degree angle.</p>

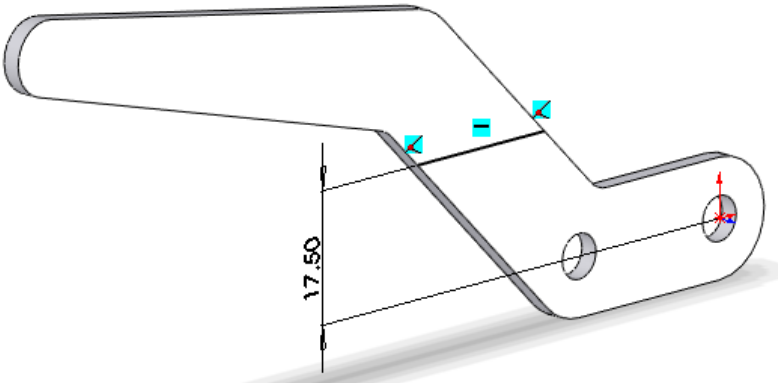
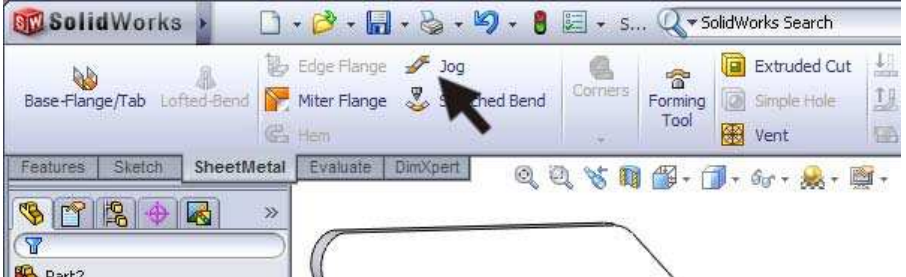
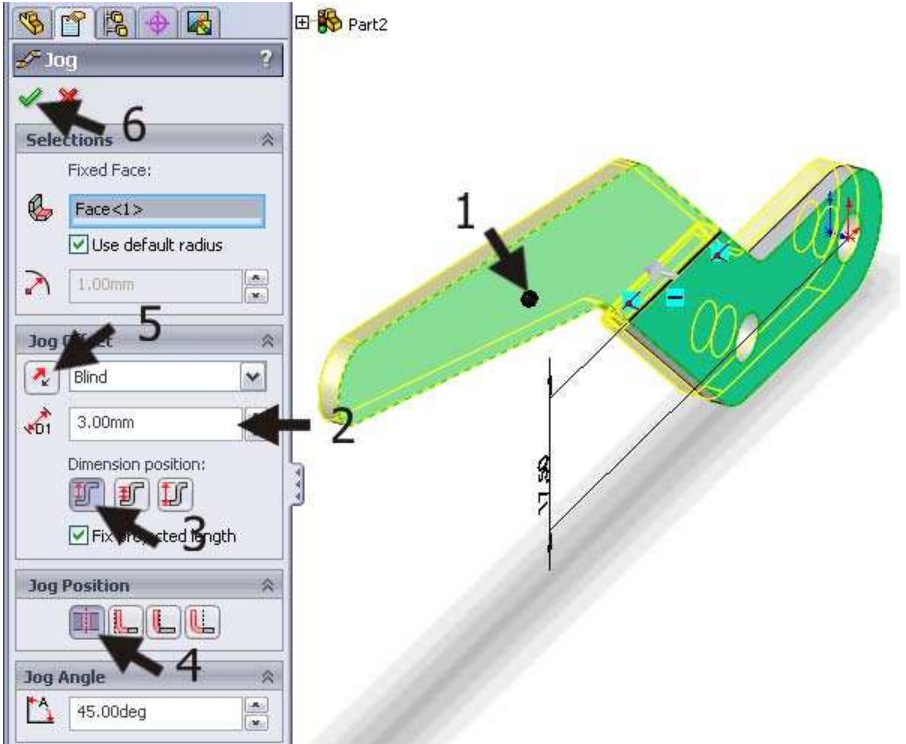
<p>59</p>	<p>We will now make a double bend in the sheet. This is called a Jog.</p> <p>Select the flat surface from the model and make the sketch as shown: it consists of one horizontal line and a dimension.</p>	
<p>60</p>	<p>Click on 'Jog' in the CommandManager.</p>	
<p>61</p>	<ol style="list-style-type: none"> 1. First, click on the part of the model that must be fixed. Click on the spot as indicated. 2. Set the distance to '3mm'. 3. This distance is called the Outside Offset. 4. Select the option Bend centerline to set the position of the jog. 5. Make sure that the jog goes backwards with the Reverse direction command as shown in the illustration. 6. Click on OK. 	

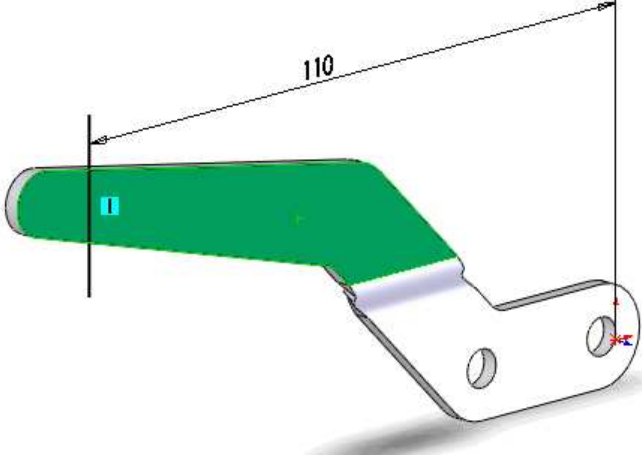
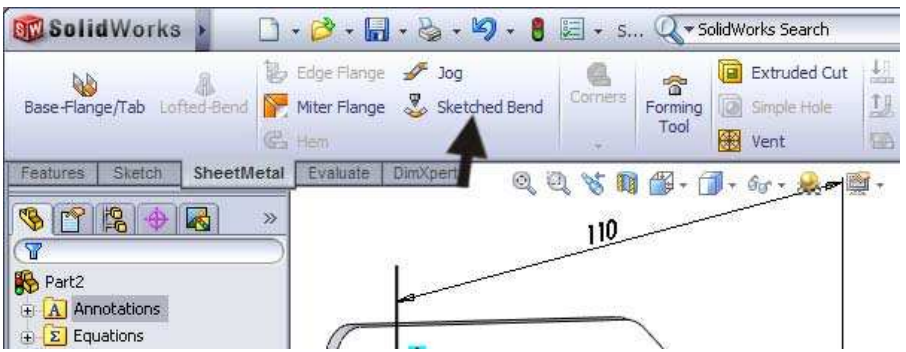
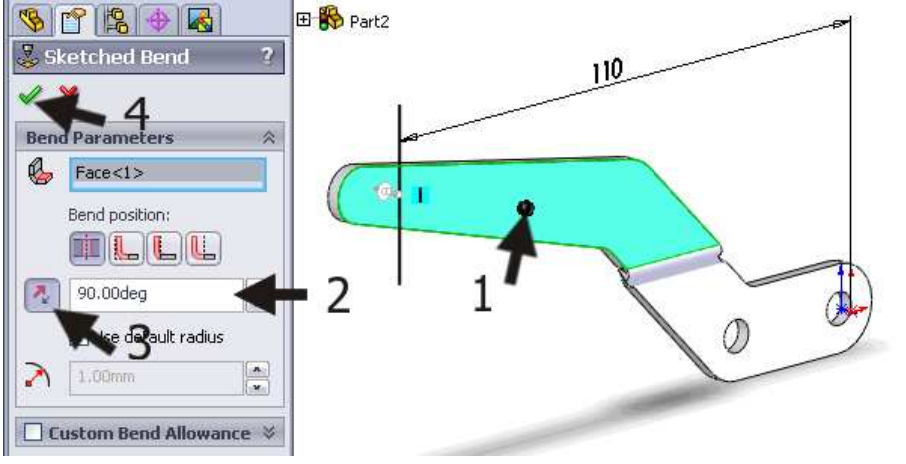
<p>62</p>	<p>Next' we have to bend the upper end of the arm.</p> <p>Select the plane as shown and make a sketch. Draw a vertical line and set the distance to '110mm' from the origin.</p>	
<p>63</p>	<p>Click on 'Sketched Bend' in the CommandManager.</p>	
<p>64</p>	<ol style="list-style-type: none"> 1. Again, you will have to indicate first which plane stays fixed. Click on the spot as indicated in the illustration. 2. Set the angel to '90°' . 3. Make sure that this part of the sheetmetal is bending in the right direction with Reverse direction. The arrow in the model indicating the direction must point backwards. 4. Click on OK. 	
<p>65</p>	<p>This model is now finished. Save it as: Arm-right.SLDPR.T.</p>	

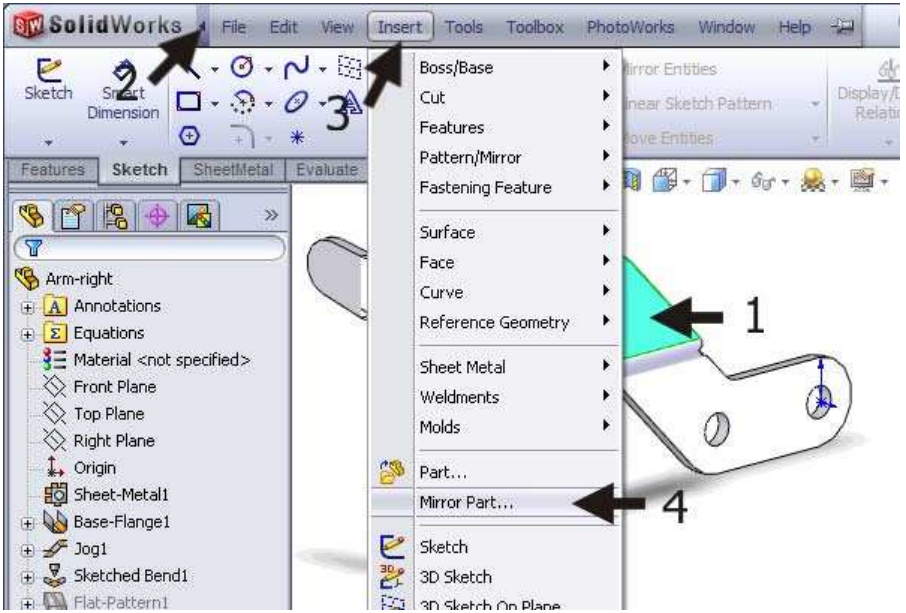
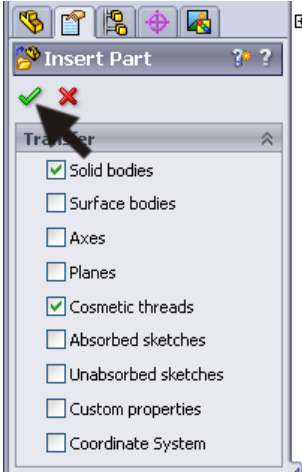
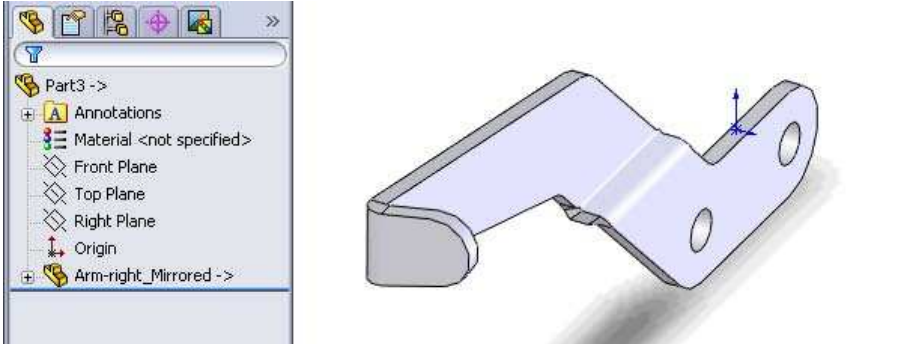
<p>66</p> <p>We need a mirrored copy from this part. This is very easy to create.</p> <ol style="list-style-type: none"> 1. Select the plane in the model as shown. This is the 'mirror' for the mirror command (the mirror 'axis'). 2. Open the pull-down menus. 3. Click on 'Insert' in the pull-down menus. 4. Click on 'Mirror Part...'. 	
<p>67</p> <p>Click on OK in the PropertyManager.</p>	
<p>68</p> <p>A new file has opened containing the mirrored part.</p> <p>This part is constrained to the original part. If you change the original, the mirrored copy will also change.</p> <p>Save this part as: Arm-left.SLDPRT.</p>	
<p>Work plan</p>	<p>The next part is a bracket. This is much simpler than the last part. How would you handle this? Make a plan!</p>

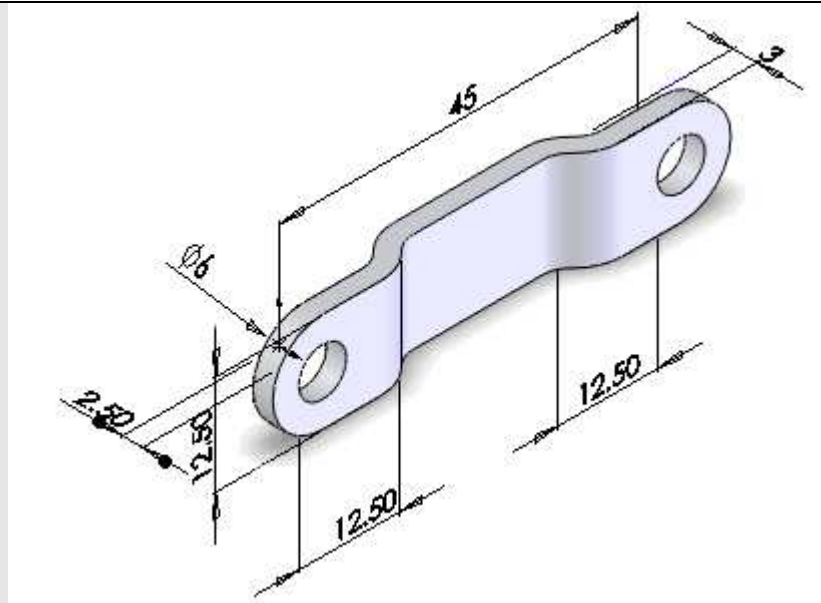

We will build this part in sheetmetal too.

69 Open a new file and make the **sketch** as shown on the **right plane**.
 When done, continue to Step 74.
 If you have trouble, follow the next few steps.

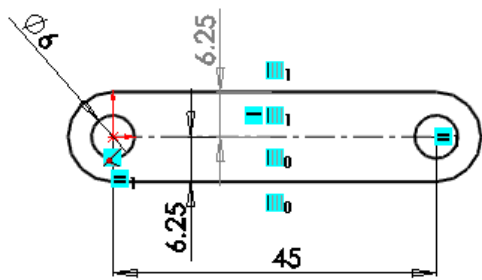

70 Draw a **centerline** horizontally to the right from the **origin**.
 Set a size for the length: **'45mm'**.

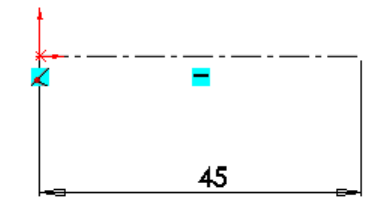

71 Draw two **circles** with the **midpoints** at both **end-points** of the **centerline**.
 Set the dimension from one of the **circles** to **'Ø6mm'**.
 Select both **circles** and set an **Equal** relation.

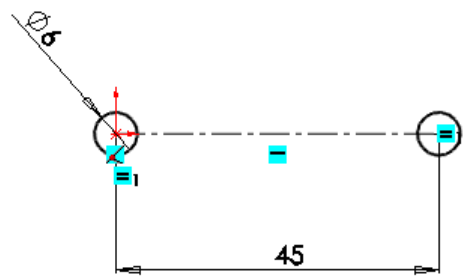

<p>72</p> <ol style="list-style-type: none"> 1. Select the centerline. 2. Click on 'Offset Entities' in the CommandManager. 3. Set a distance of '6.25mm' in the PropertyManager. 4. Check the option 'Bi-directional'. 5. Check the option 'Cap ends' and next check 'Arcs'. 6. Click on OK. 	
<p>73</p> <p>First, click on 'SheetMetal' in the CommandManager then on 'Base Flange'.</p>	
<p>74</p> <ol style="list-style-type: none"> 1. Set the thickness of the material to '2.5mm' in the PropertyManager. 2. Click on OK. 	

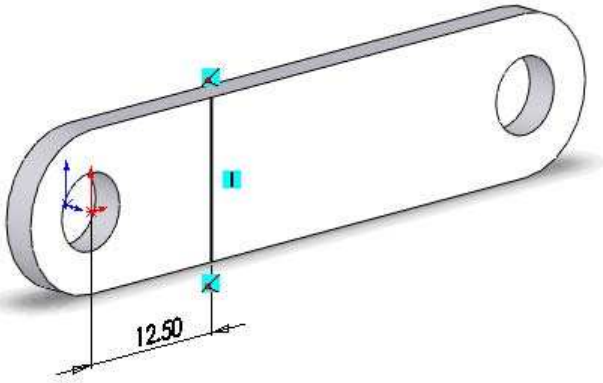
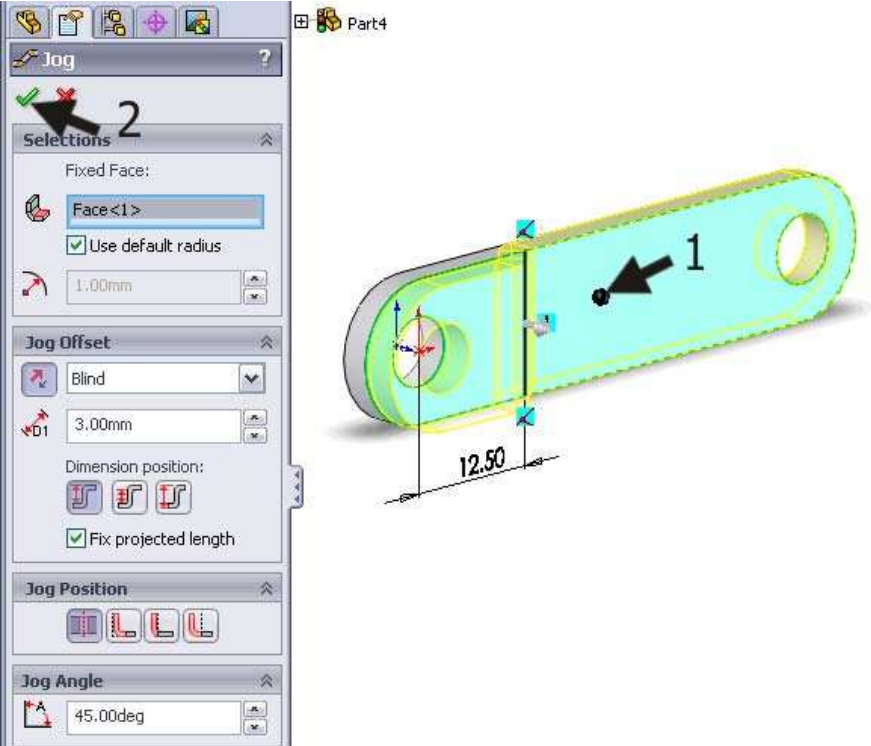
<p>75</p>	<p>Make the sketch as shown. Draw a vertical line and set the dimension from that line to the center of the left hole to '12.5mm'.</p>	
<p>76</p>	<p>Click on 'Jog' in the CommandManager and set the following features in the PropertyManager:</p> <ol style="list-style-type: none"> 1. Click on the middle of the model to determine the fixed plane. 2. All other settings will be the same as the last time you did this. So you do not have to change them. Check the settings with the data from the illustration. 3. Click on OK. 	

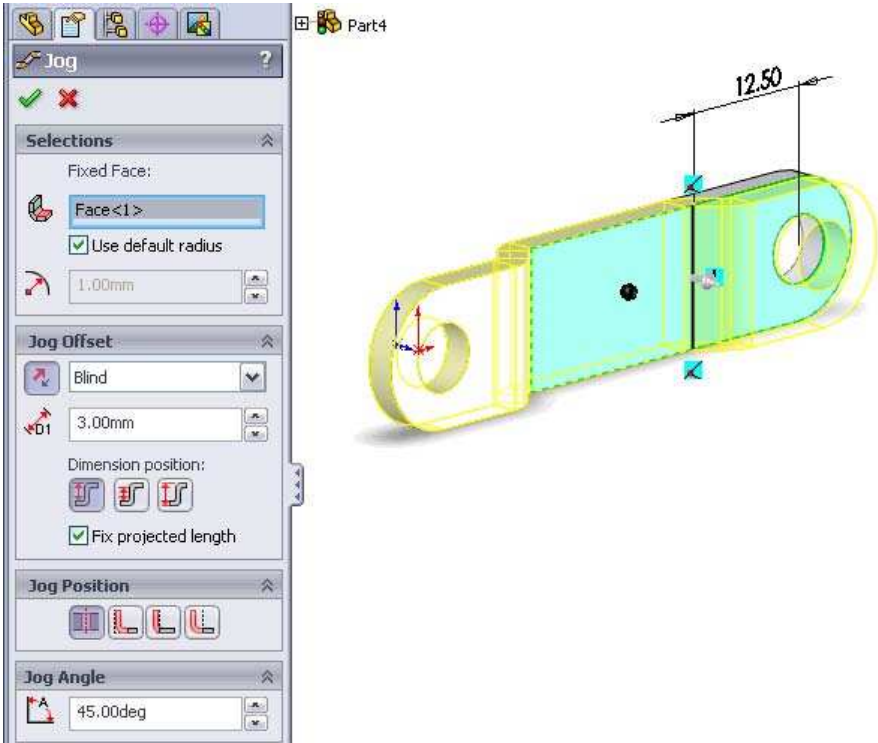
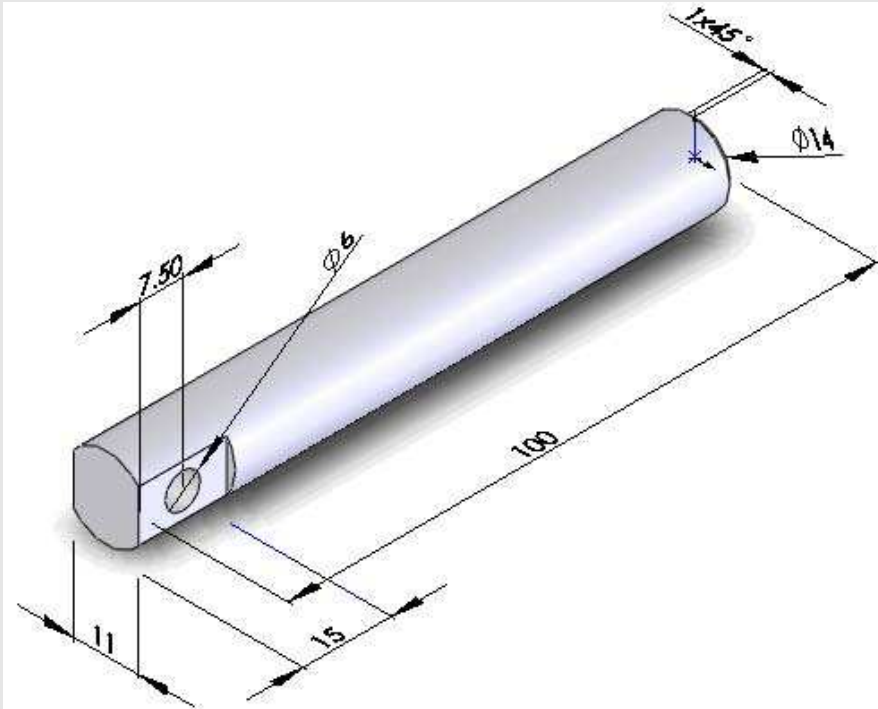
<p>77</p>	<p>Make a second 'Jog' at the other end of the bracket. Do exactly the same as you did in the last two steps, only now set the vertical line '12.5mm' from the right hole.</p>	 <p>The screenshot shows the SolidWorks 'Jog' feature properties for 'Part4'. The 'Jog' feature is applied to 'Face<1>' with a radius of 1.00mm. The 'Jog Offset' is set to 'Blind' with a depth of 3.00mm. The 'Jog Position' is set to 'Fix projected length'. The 'Jog Angle' is 45.00deg. The 3D model shows a bracket with a jog feature at the right end, with a dimension of 12.50mm from the right hole to the jog.</p>
<p>78</p>	<p>Save the file as: link.SLDPRT.</p>	
		<p>We will make the pin now. This is a simple part that you can probably make by yourself without any problem. We only provide the main steps.</p>  <p>The 3D model shows a cylindrical pin with the following dimensions: total length of 100mm, outer diameter of 14mm (Ø14), an inner hole with a diameter of 6mm (Ø6) and a depth of 7.50mm. The hole is offset by 11mm from the left end. The hole diameter is also indicated as 15mm. The right end of the pin has a chamfer with a 45-degree angle (1x45°).</p>

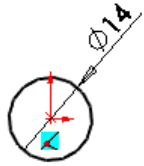
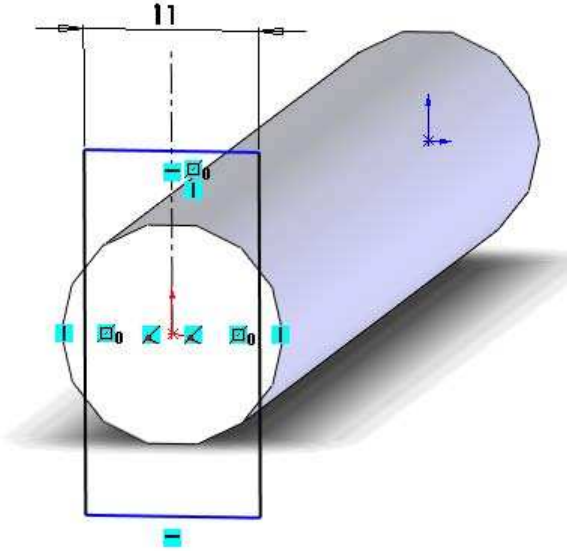
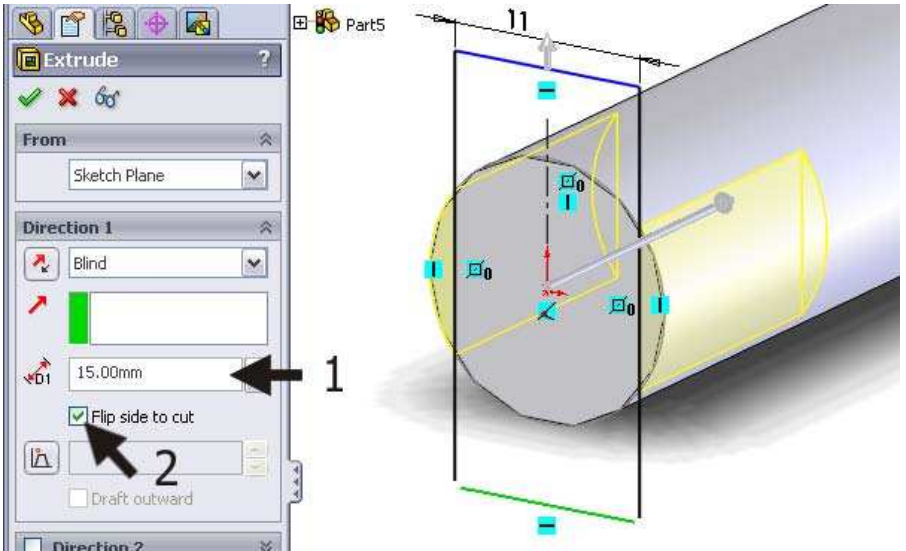
<p>79</p>	<p>Open a new part and make the sketch as shown on the front plane. It consists only of one circle.</p> <p>Extrude this circle with a length of '100mm'.</p>	
<p>80</p>	<p>Make a sketch as shown. Use the centerline to make sure that the rectangle is exactly in the middle of the circle. The height of the rectangle does not matter.</p>	
<p>81</p>	<p>Make an Extruded Cut from this sketch.</p> <ol style="list-style-type: none"> 1. The depth is '15mm'. 2. Check the option 'Flip side to cut' to make sure that the material on the outside of the rectangle will be removed and not on the inside, like we would do with a normal Extruded Cut. 	

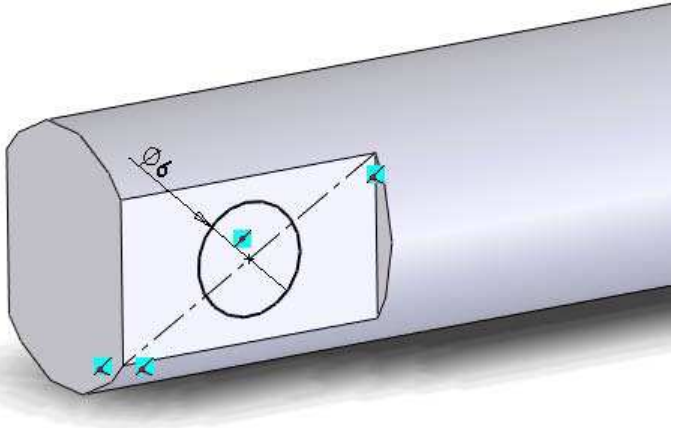
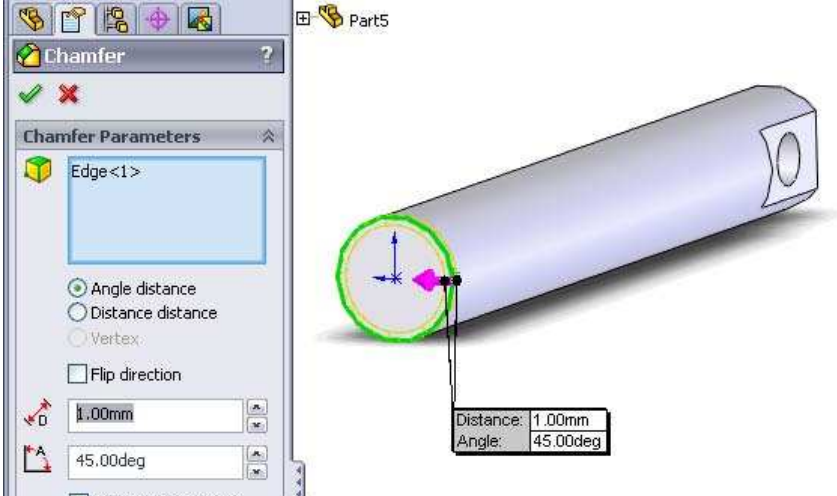
<p>82</p>	<p>Make the sketch as shown. Draw the diagonal center-line. Next draw a circle on the midpoint of the center-line.</p> <p>Make an Extruded Cut with a depth set to 'Through All' from this sketch.</p>	
<p>83</p>	<p>Finally, chamfer the end of the pin by '1mm x 45°' using the Chamfer feature.</p>	
<p>84</p>	<p>Save the file as Rod.SLDPRT.</p>	

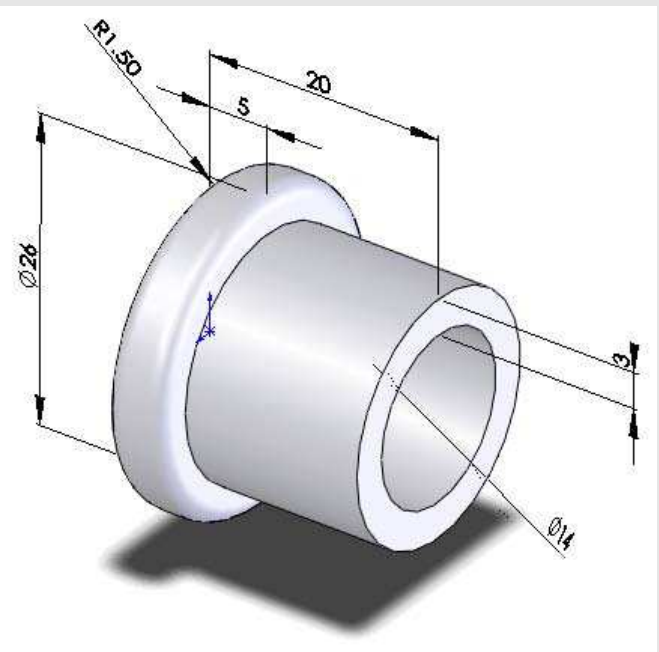
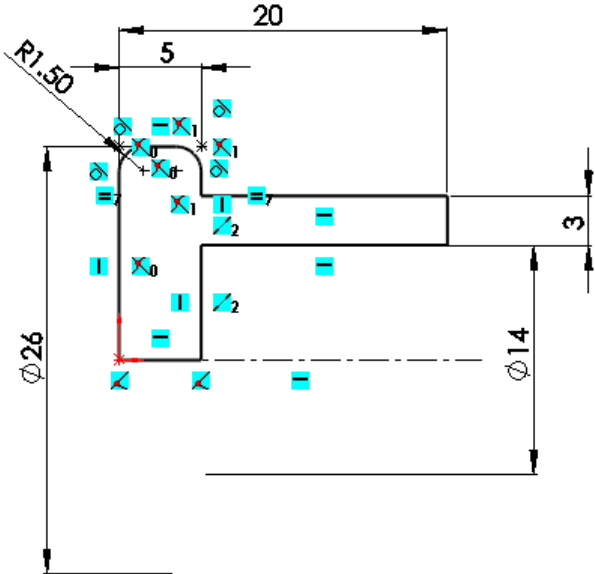
	<p>Work plan</p>	<p>The next part is the cap. It only consists of one feature: a Revolved Boss.</p> 
<p>85</p>	<p>Open a new part and make the sketch as shown on the front plane.</p> <p>Make the sketch complete without any fillets. Only when the sketch is done, use the Sketch Fillet command.</p> <p>Make a Revolved Boss, over '360°' from this sketch.</p>	
<p>86</p>	<p>Save the file as Sock-et.SLDPRT.</p>	

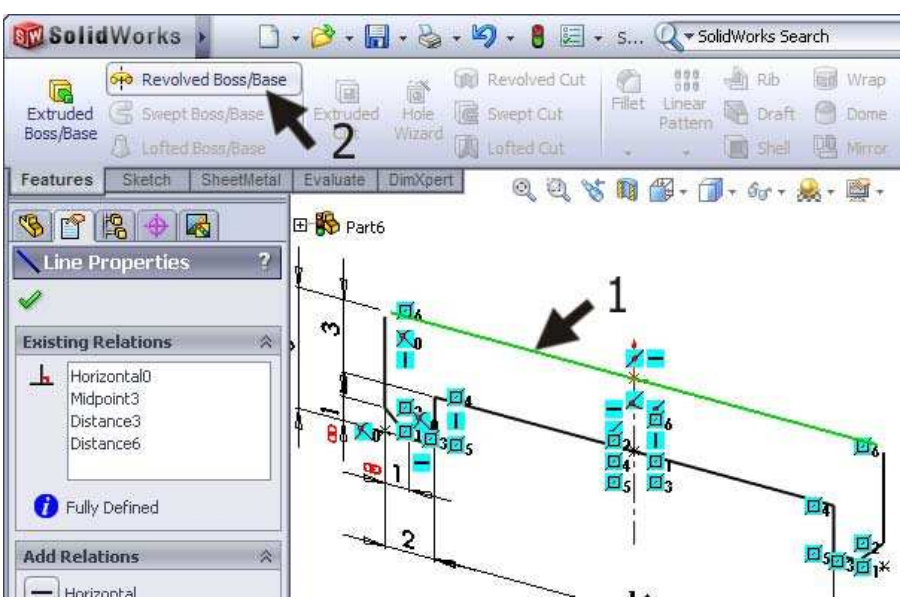
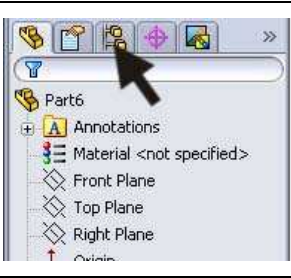
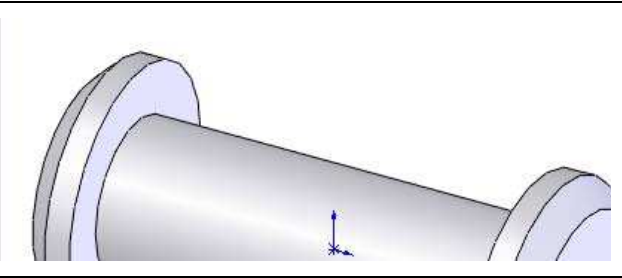
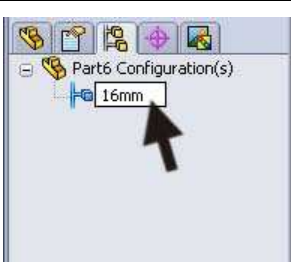
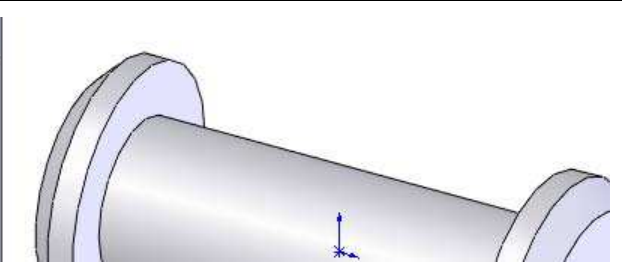
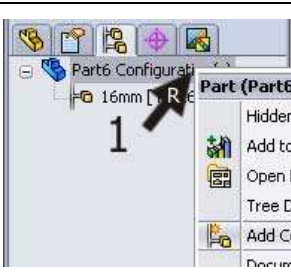
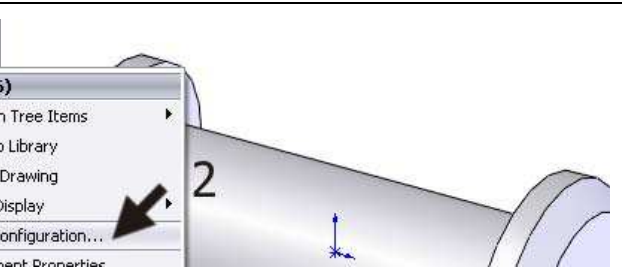
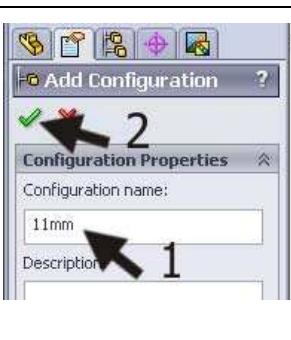
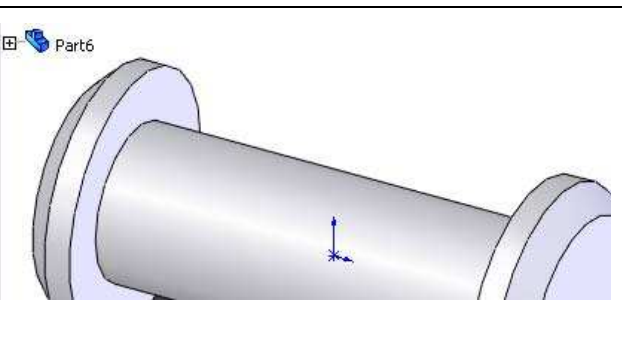
<p>88</p> <ol style="list-style-type: none"> 1. Select the upper horizontal line in the sketch. This will be our rotation axis. 2. Click on 'Revolved Boss/Base'. <p>Click on OK in the PropertyManager to make the rotation.</p>	
<p>89</p> <p>Go to the Configuration-Manager.</p>	 
<p>90</p> <p>Change the name of the current configuration from 'Default' to '16mm'.</p>	 
<p>91</p> <p>Add a new configuration.</p> <ol style="list-style-type: none"> 1. Right-click on the upper line. 2. Click on 'Add configuration...'. 	 
<p>92</p> <ol style="list-style-type: none"> 1. Name for the new configuration '11mm'. 2. Click on OK. 	 

<p>93</p>	<ol style="list-style-type: none"> 1. Double-click on the model. The dimensions appear. 2. Double-click on the dimension '16mm'. The 'Modify' menu appears. 3. Change the size to '11mm'. 4. Select 'This configuration'. The changed value will only be altered in the active configuration now and not in the other one. 5. Click on Rebuild to activate the changes. 6. Click on OK. 	
<p>94</p>	<p>This part is ready too. Save it as Rivet.SLDPRT.</p>	
<p>95</p>	<p>All parts of the clamp are now ready, so we can start building the assembly. Try it yourself first. If you fail, follow the steps below.</p> <p>Open a new assembly.</p>	
<p>96</p>	<p>Place the base in the assembly, next the pin and the cap. You can place all items at random on the screen.</p>	

<p>97</p> <ol style="list-style-type: none"> 1. Click on 'Mate' in the CommandManager. 2,3 Select the two planes from the pin and the base as illustrated on the right. 4. Because the pin is in the wrong direction, you must click on Anti-Aligned in the CommandManager. The pin is reversed now. 5. Click on OK. 		
<p>98</p> <p>Select the two planes as shown.</p> <p>Click on OK.</p>		

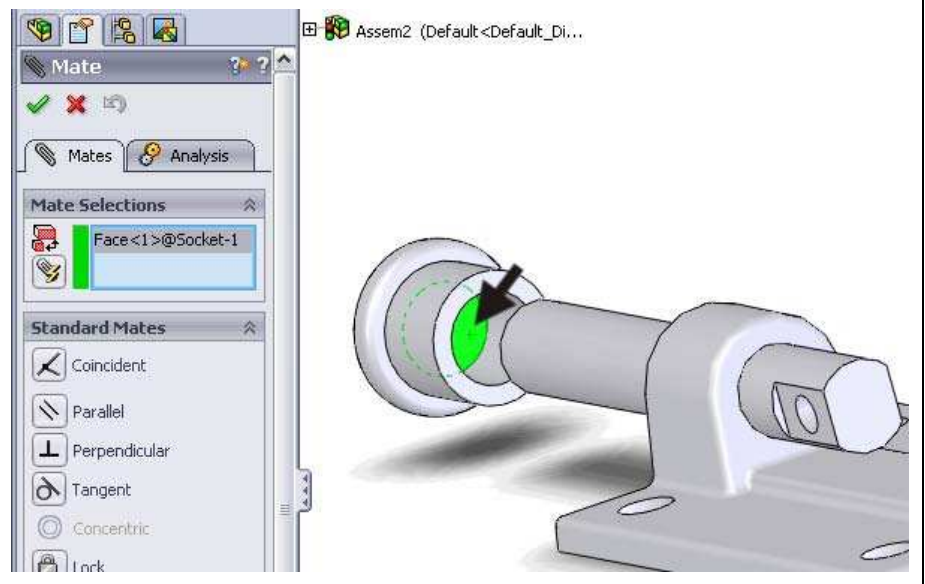
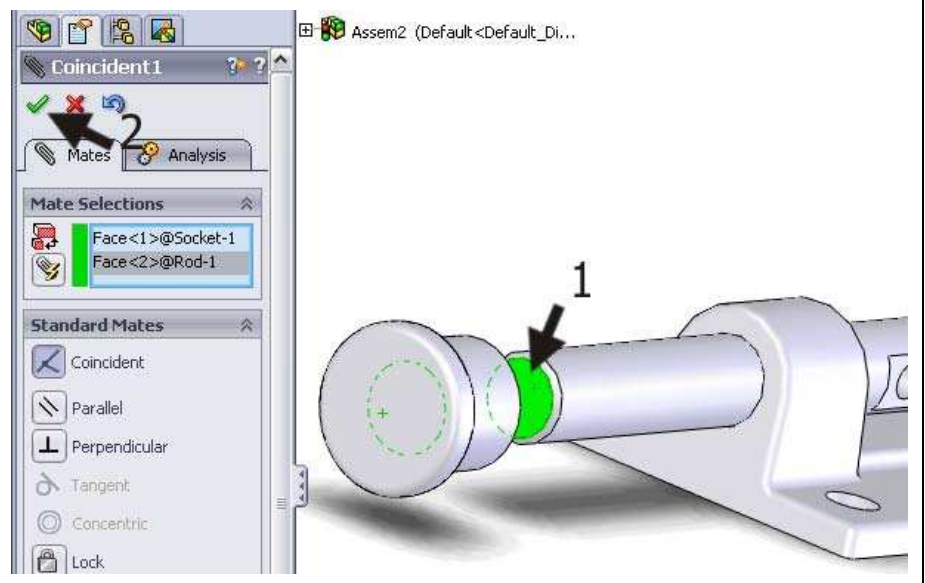
<p>99</p>	<p>Select the surface at the inside of the cap as shown.</p>	
<p>100</p>	<ol style="list-style-type: none"> 1. Rotate the model and select the plane from the axis as shown. 2. Double-click on OK to end the Mate command. 	

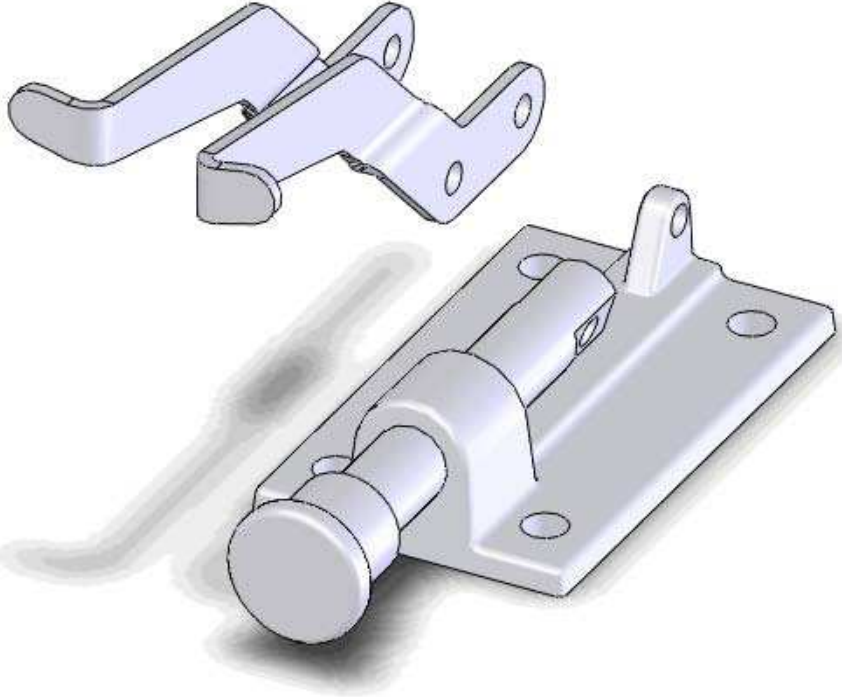
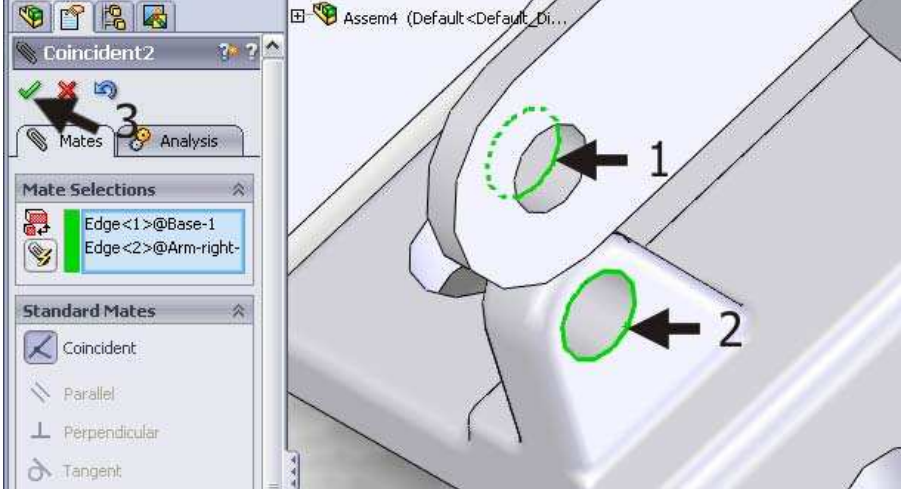
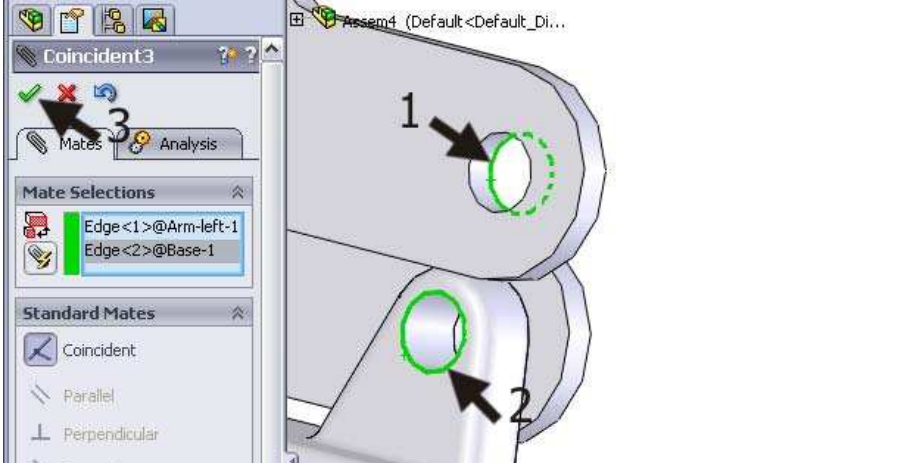
<p>101</p>	<p>Use 'Insert Component' to put the two arms in the assembly.</p>	
<p>102</p>	<p>Click on 'Mate' in the CommandManager again.</p> <p>Select the two edges as shown.</p> <p>Click on OK.</p>	
<p>103</p>	<p>Rotate the model and do the same again for the other arm.</p>	

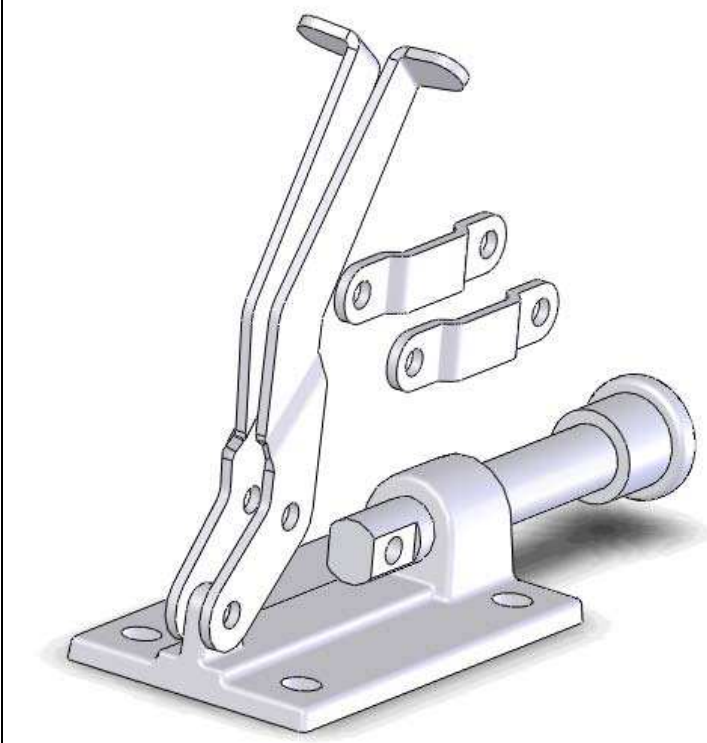
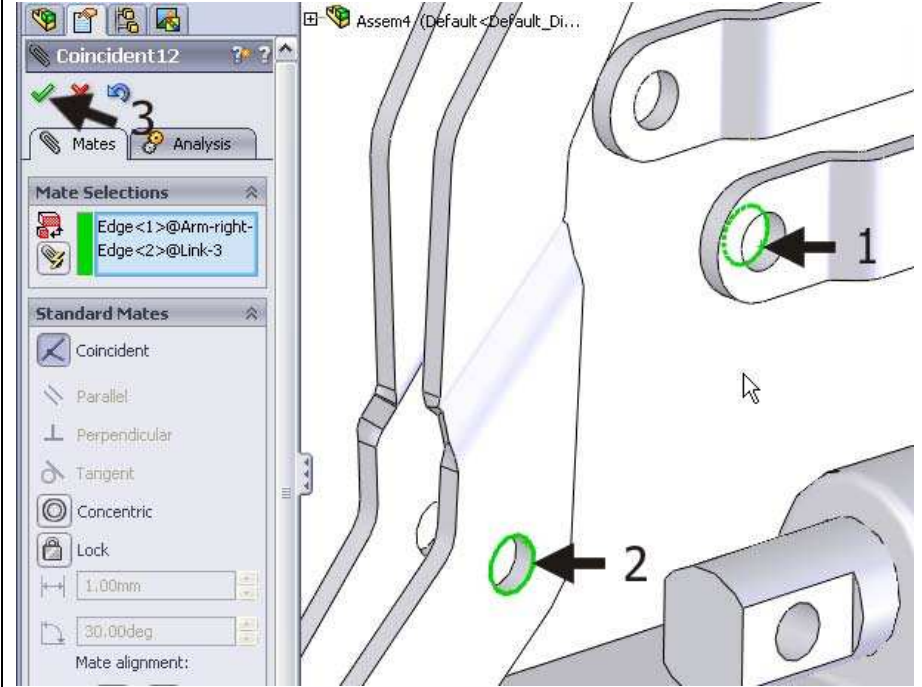
<p>105 Try to drag the parts around the screen now. You will notice that you can only move the pin and the cap up and down and rotate the arms. These movements are determined by the mates you have added.</p> <p>Add two brackets to the assembly.</p>	
<p>106 Start the Mate command again and make a 'Coincident' mate (not a 'Concentric'!)</p> <p>Select the two edges as shown on the right.</p> <p>Click on OK.</p>	

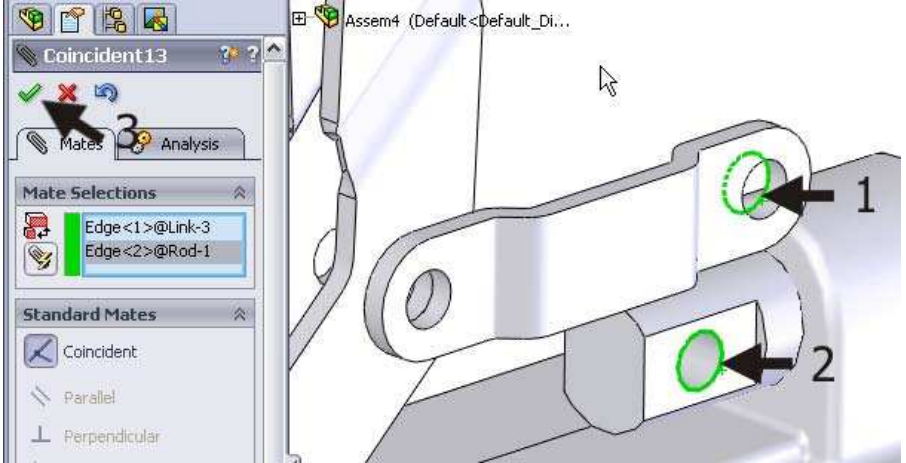
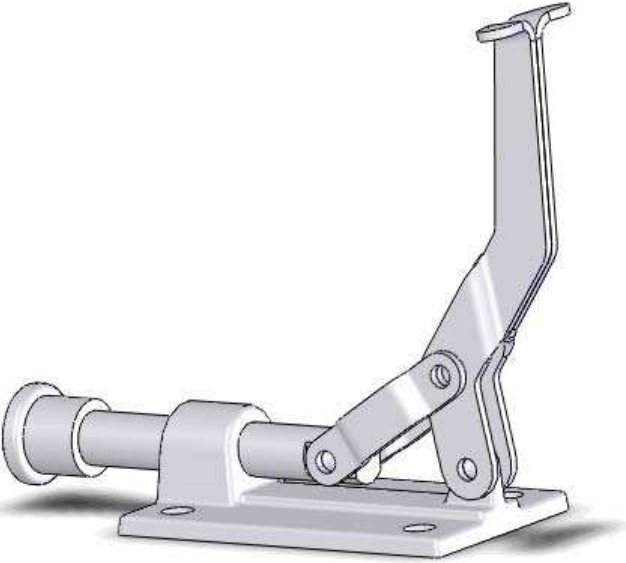

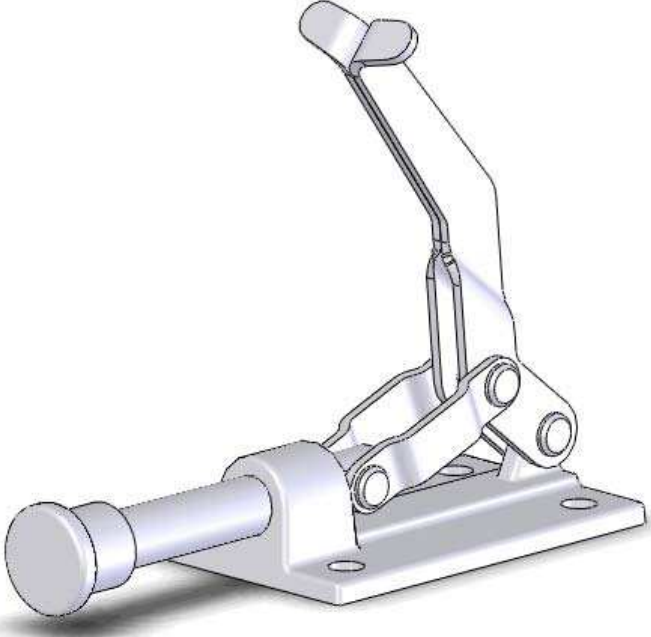
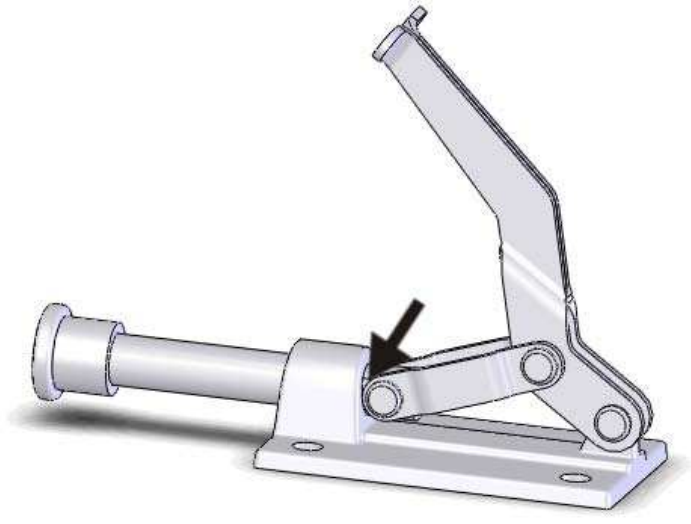
<p>107</p>	<p>Select the two edges as shown. Click on OK.</p>	
<p>108</p>	<p>Set the other bracket as well. Use the option Anti-Aligned to reverse the bracket.</p>	

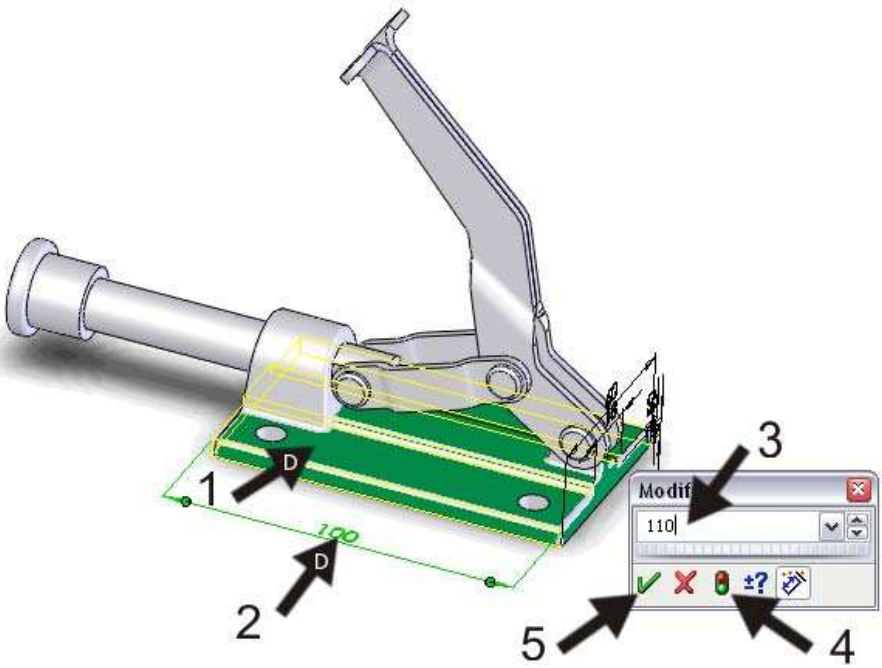
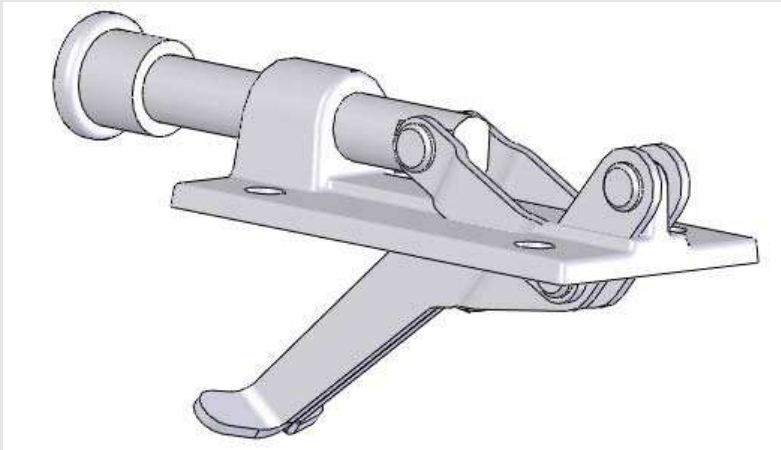
<p>109</p>	<p>You can move the arm now and you will see the clamp functioning.</p> <p>To finish the model you need to add the rivets. You will need one rivet of '11mm' and two rivets of '16mm'.</p>	
<p>110</p>	<p>The assembly is ready now. Save the file as Clamp.SLDASM.</p>	
	<p>Checking the model</p>	<p>When you move the arm of the clamp, you will notice that the brackets collide with the base.</p> <p>To solve this problem, we need to extend the base a bit.</p> 

<p>111</p>	<p>The easiest way to extend the size of the base is to do the following:</p> <ol style="list-style-type: none"> 1. Double-click on the base. The dimensions appear. 2. Find the length (100) and double-click on this. The 'Modify' menu appears. 3. Change the size to '110mm'. 4. Click on Rebuild, and check to see if the change is correct. 5. Click on OK. 	
	<p>Checking the model</p>	<p>The arm from the pin can rotate 360 degrees and in the software, the arm goes right through the material of the base. This is not possible in the real world, so we want to limit the rotation of the arm.</p> 

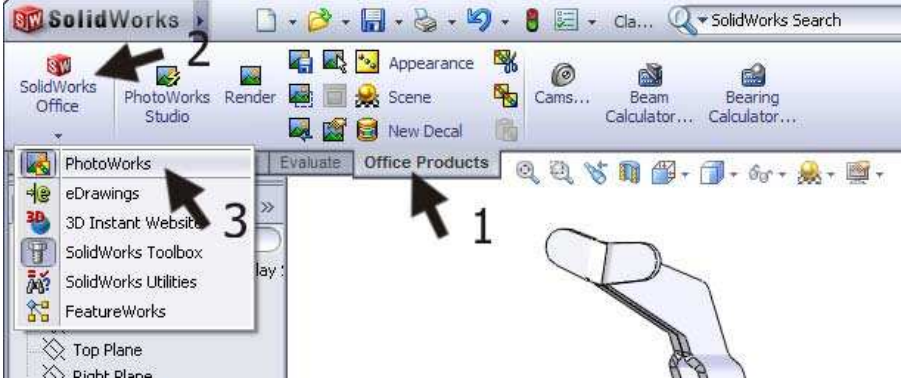
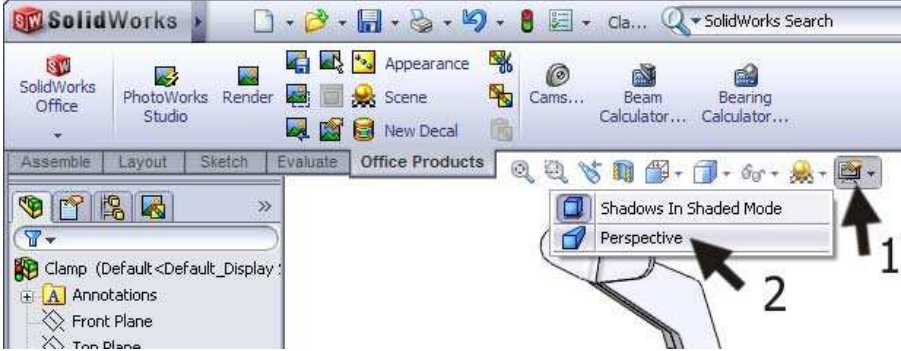
<p>112</p> <p>To find out the most extreme positions, we will follow the next few steps:</p> <ol style="list-style-type: none"> 1. Make sure the arm is pointing upward. 2. Click on 'Move Component' in the CommandManager. 3. Select the option 'Collision Detection' in the PropertyManager. 4. Check the function 'Stop at collision'. 		
<p>113</p>	<p>Move the arm again. Notice that the movement is limited to the position where two parts collide. At that point, the colliding parts turn green.</p>	

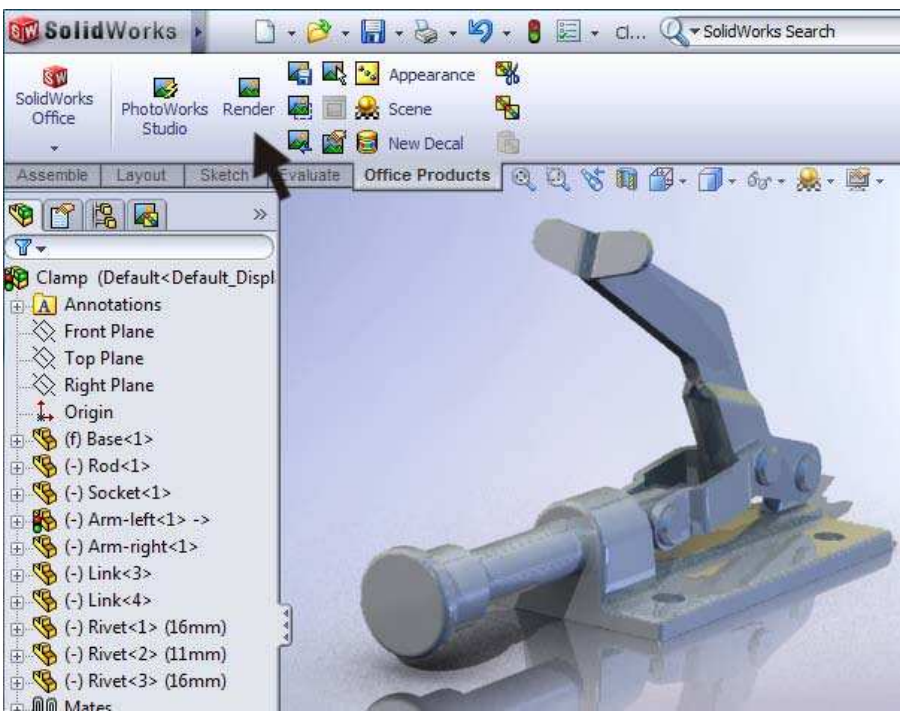
	<p>Work plan</p>	<p>Finally, we will make a rendering from this model. A rendering is a picture of the model with all features displayed as realistically as possible. You can use a rendering for many communications purposes, such as in a presentation.</p> <p>To make a rendering in SolidWorks we use a separate piece of software called PhotoWorks. This is a very robust program with a wide range of capabilities. We will show you how to make a standard rendering using the default settings.</p>
<p>114</p>	<p>Check to see if PhotoWorks is activated.</p> <ol style="list-style-type: none"> 1. Click on the tab 'Office Products' in the CommandManager. <p>When the button 'PhotoWorks Studio' is present, you are ready with this application.</p> <ol style="list-style-type: none"> 2. If the button 'PhotoWorks Studio' is not visible, click on 'SolidWorks Office'. 3. Click on 'PhotoWorks'. <p>The buttons and functions for PhotoWorks appear in the CommandManager now.</p>	
<p>115</p>	<p>Put the model in perspective. This will give a more natural look than an isometric or diametric view.</p> <ol style="list-style-type: none"> 1. Click on View Settings. 2. Click on 'Perspective'. <p>Rotate the model to establish the view that you want to show in the rendering.</p>	

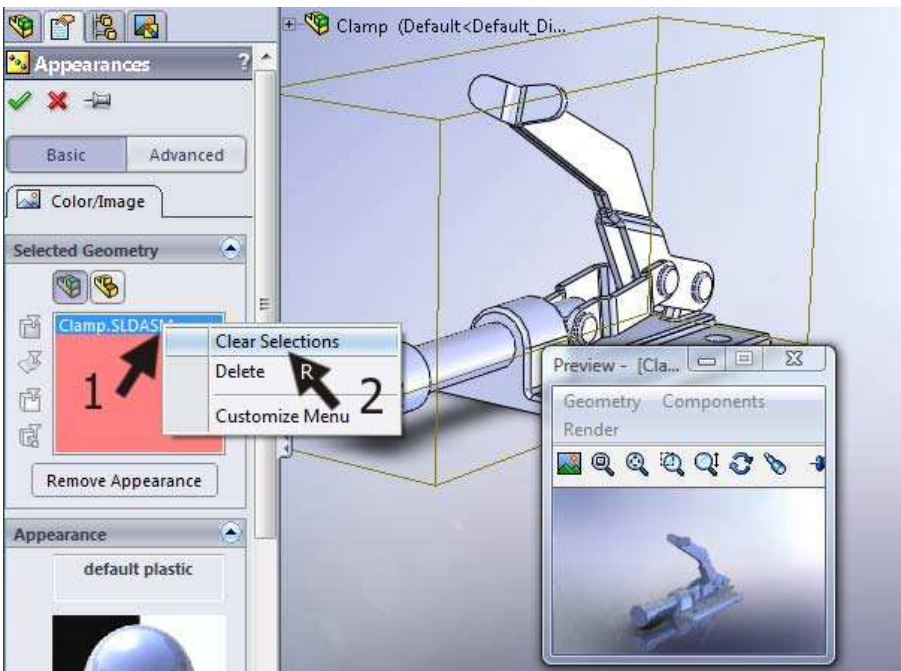
<p>116 First, we will make a rendering with the default settings.</p> <p>Click on 'Render' in the CommandManager.</p> <p>You will notice that the image is displayed differently, including shadows and reflections.</p>	
<p>117 We will determine the kind of material for the different parts.</p> <p>Click on 'Appearance' in the CommandManager.</p>	
<p>118 You will see a small 'Preview' window in which you can see your settings. You can close the window if you want, you will not need it in this exercise.</p> <p>The whole assembly is selected now.</p> <ol style="list-style-type: none"> 1. Right-click on 'Clamp.SLDASM' in the PropertyManager. 2. Click on 'Clear Selections'. 	

<p>119</p>	<ol style="list-style-type: none"> 1. Check the option Apply changes at assembly component level in the PropertyManager. 2. Click on the cap in the model. 	
<p>120</p>	<ol style="list-style-type: none"> 1. Click on the tab RealView/PhotoWorks Items (on the right side of your screen) in the task pane. 2. Click on 'Rubber'. 3. Click on 'Matte'. 4. You will only find one kind of material in this category. Select it. <p>The cap is now made of 'matte rubber'.</p>	
<p>121</p>	<ol style="list-style-type: none"> 1. Click on the pushpin in the PropertyManager. The PropertyManager will remain visible even after you have clicked OK. This will come in handy when you are going to determine the kind of material to use for several parts. 2. Click on OK. 	

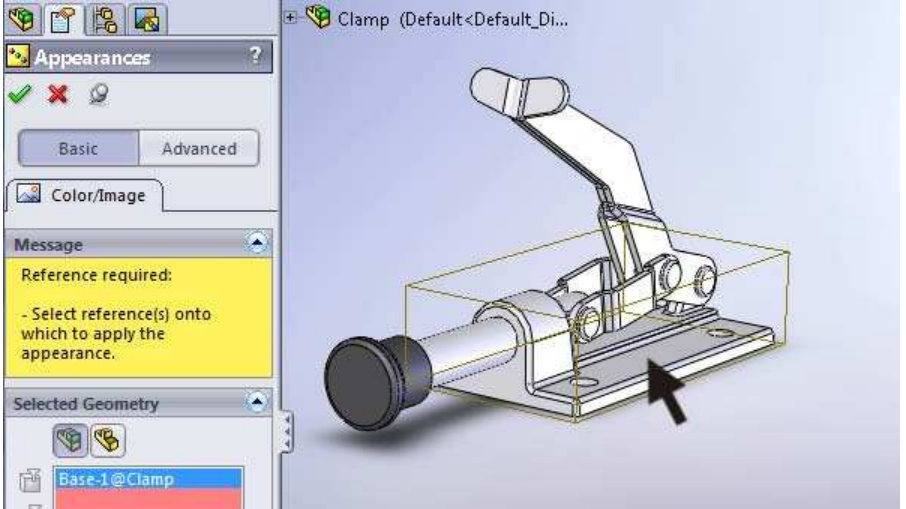
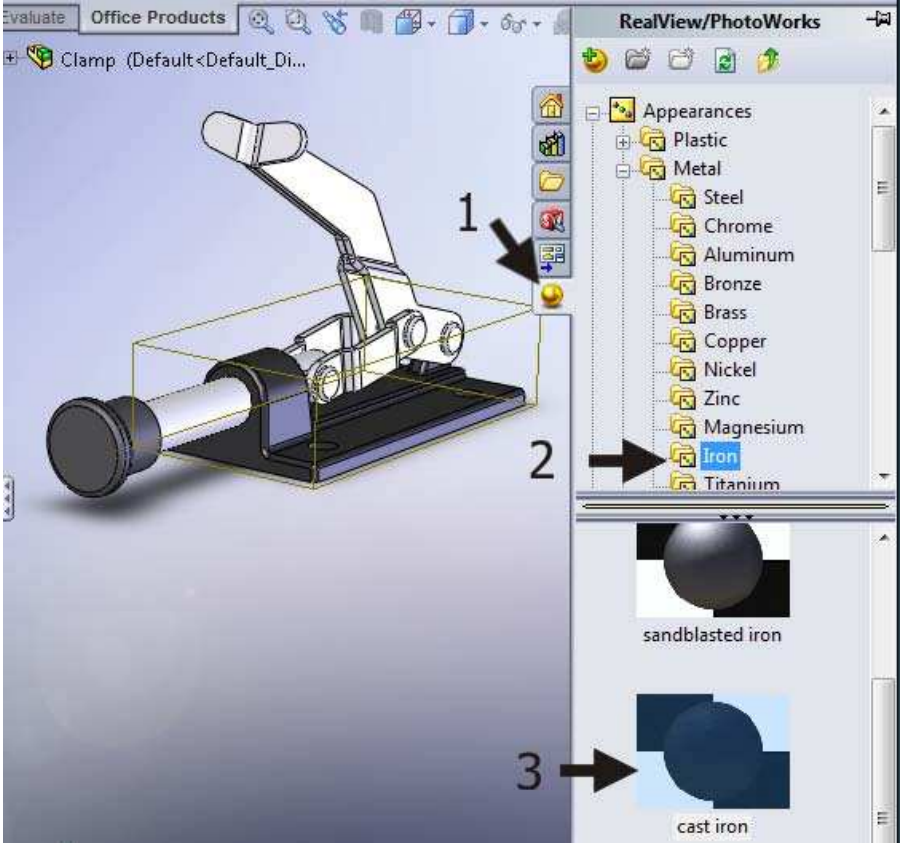
<p>122</p>	<p>Select the base in the model.</p>	
<p>123</p>	<p>Select 'cast iron'. Click on OK in the PropertyManager.</p>	
<p>124</p>	<p>You can do the same with all of the other parts yourself. You can also determine colors for the different parts. Try this or keep the default settings.</p>	

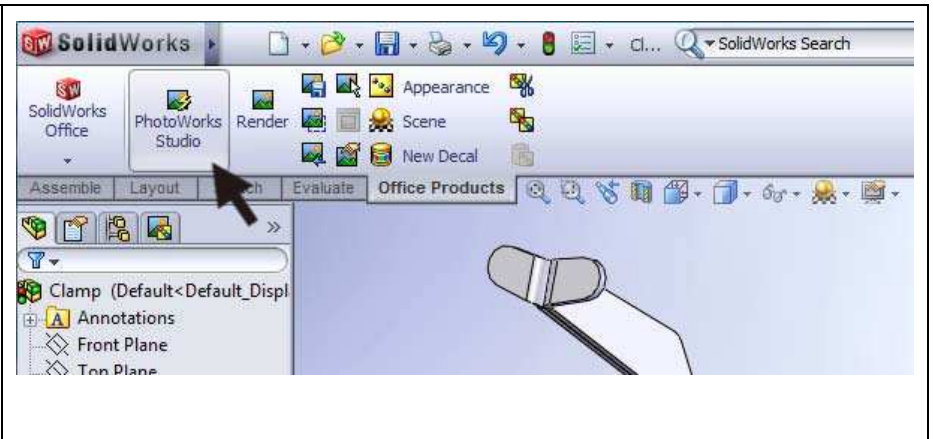
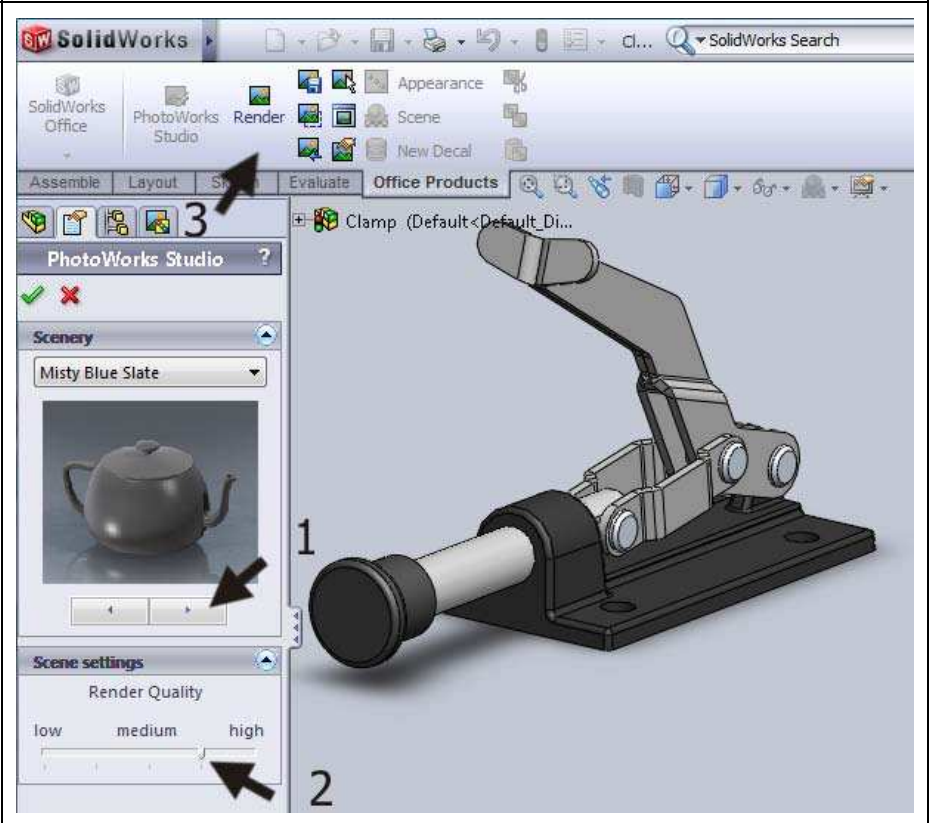
<p>125</p>	<p>Now that we have determined the materials, we can set the 'scene' around a product. The scene is the environment, the background, and/or the lighting. SolidWorks has a number of standard scenes.</p> <p>Click on 'PhotoWorks Studio' in the CommandManager.</p>	 <p>The screenshot shows the SolidWorks CommandManager ribbon. The 'PhotoWorks Studio' button is highlighted with a black arrow. Other buttons like 'Render', 'Scene', and 'New Decal' are also visible. The background shows a 3D model of a clamp.</p>
<p>126</p>	<ol style="list-style-type: none"> 1. You can browse the available scenes in the PropertyManager. Every time you will be presented with the preview. Select one scene and use it. 2. Set the 'Render Quality' at least to 'medium' or you will not see any shadows. 3. Click on 'Render' in the CommandManager. 	 <p>The screenshot shows the SolidWorks PropertyManager for 'PhotoWorks Studio'. The 'Scenery' section shows a preview of a teapot under a 'Misty Blue Slate' scene. The 'Scene settings' section shows the 'Render Quality' slider set to 'medium'. A black arrow labeled '1' points to the 'Render' button in the CommandManager, and another black arrow labeled '2' points to the 'Render Quality' slider. A third black arrow labeled '3' points to the 'PhotoWorks Studio' button in the CommandManager. The background shows a 3D model of a clamp.</p>

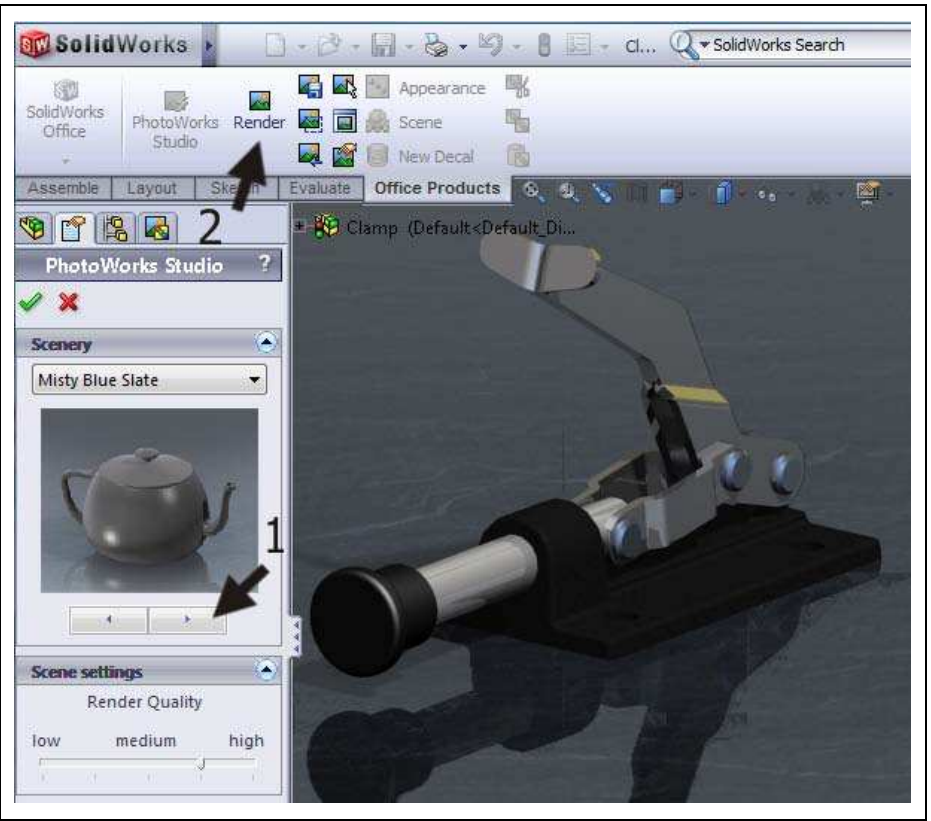
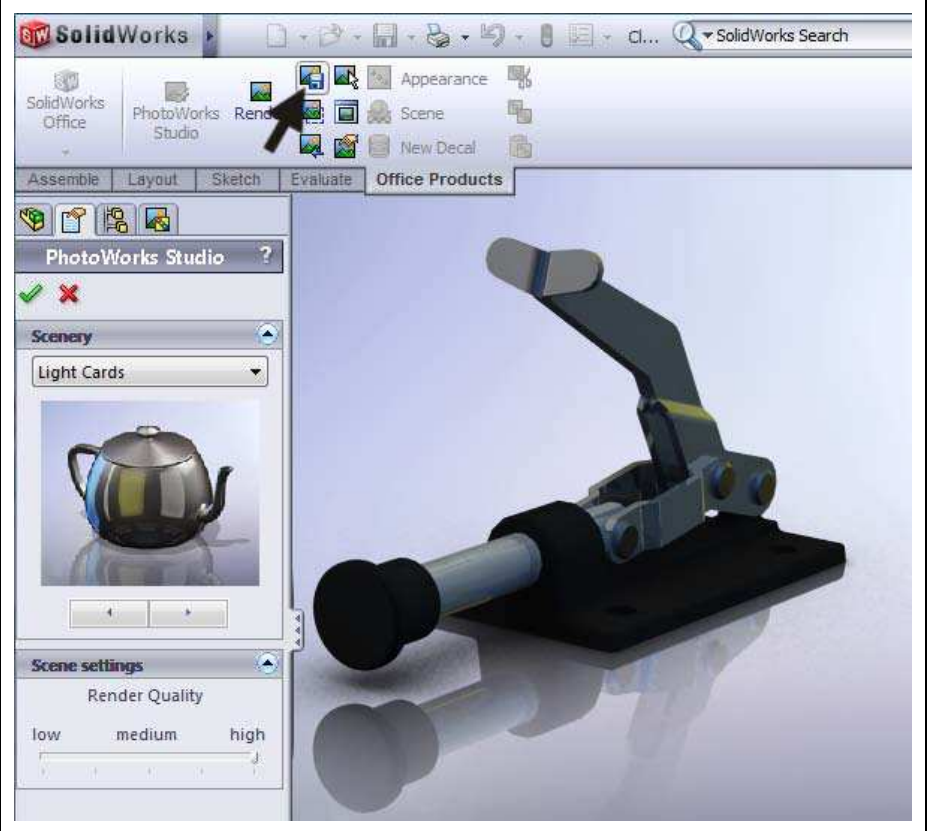
<p>127</p>	<p>The rendered image appears. You can browse to another scene in the PropertyManager and click on 'Render' again.</p>	
<p>Hint!</p>		<p>The rendering sometimes takes a while, especially when you use high quality with a lot of light sources and shadows. To speed this process up, you can render a part of the model. Click on 'Render Area' in the CommandManager and indicate on the screen which part of it you want to render.</p>
<p>128</p>	<p>Did you find the rendering you wanted, you can save it in a separate file, for instance in JPEG format. You can use it for a report or on a website.</p> <p>Click on Render to file.</p>	

<p>129</p>	<p>Set the following features in the menu that appears:</p> <ol style="list-style-type: none"> 1. Select a name for the file, 'Clamp'. 2. Select a file format. 'JPEG' can be used by a lot of applications. 3. Select the 'Image size'. This depends on what you want to do with it, but a width of between 1000 and 2000 pixels is usually sufficient. The height will adapt itself automatically. 4. Click on 'Render'. 	
<p>Hint!</p>	<p>What you have just seen in PhotoWorks is only the beginning of what you can do with this application. You can change whatever you like: the background, the surface, the lighting, and so on. These steps are not included in this tutorial, but if you are interested, try them yourself.</p>	
<p>What are the main features you have learned in this tutorial?</p>	<p>In this tutorial you have learned a few new tools.</p> <ul style="list-style-type: none"> • You have used Jogs in the sheetmetal features. • You have used the Draft feature to add sloped planes to the model. • You have seen how to limit the movement in an assembly. • You have used PhotoWorks. • The most important thing you have gained, however, is the practice the tutorial has provided in modeling and, even more importantly, making sketches. <p>This is the last tutorial from SolidWorks in this series. When you have completed all twelve exercises and have done some additional practice, you should be able to work with SolidWorks quite well now.</p> <p>To get even better, all you need to do is practice, practice, and practice some more!</p> <p>Not all of the features in SolidWorks were presented in these tutorials. That would be virtually impossible, given the vast possibilities and features in the software.</p>	

		<p>You are now a SolidWorks 'user' and that means you can try and build something on your own. And you will learn a lot from this! And if you fail with one or more functions, find the Help function. It will help you to get on with your work. For Dutch students, it is possible to get a book called 'Productmodelleren met SolidWorks' in which practically all possibilities from SolidWorks are described.</p> <p>Do not be afraid to try things yourself and keep on practicing. You will soon be able to call yourself a SolidWorks expert!</p>
--	--	---

SolidWorks works in education

One cannot imagine the modern technical world without 3D CAD. Whether your profession is in the mechanical, electrical, or industrial design fields, or in the automotive industry, 3D CAD is THE tool used by designers and engineers today.

SolidWorks is the most widely used 3D CAD design software in Benelux. Thanks to its unique combination of features, its ease-of-use, its wide applicability, and its excellent support. In the software's annual improvements, more and more customer requests are implemented, which leads to an annual increase in functionality, as well as optimization of functions already available in the software.

Education

A great number and wide variety of educational institutions – ranging from technical vocational training schools to universities, including Delft en Twente, among others – have already chosen SolidWorks. Why?

For a **teacher** or **instructor**, SolidWorks provides user-friendly software that pupils and students find easy to learn and use. SolidWorks benefits all training programs, including those designed to solve problems as well as those designed to achieve competence. Tutorials are available for every level of training, beginning with a series of tutorials for technical vocational education that leads students through the software step-by-step. At higher levels involving complex design and engineering, such as double curved planes, more advanced tutorials are available. All tutorials are in English and free to download at www.solidworks.com.

For a **scholar** or a **student**, learning to work with SolidWorks is fun and edifying. By using SolidWorks, design technique becomes more and more visible and tangible, resulting in a more enjoyable and realistic way of working on an assignment. Even better, every scholar or student knows that job opportunities increase with SolidWorks because they have proficiency in the most widely used 3D CAD software in the Benelux on their resume. For example: at www.cadjobs.nl you will find a great number of available jobs and internships that require SolidWorks. These opportunities increase motivation to learn how to use SolidWorks.

To make the use of SolidWorks even easier, a Student Kit is available. If the school uses SolidWorks, every scholar or student can get a **free download** of the Student Kit. It is a complete version of SolidWorks, which is only allowed to be used for educational purposes. The data you need to download the

Student Kit is available through your teacher or instructor.

The choice to work with SolidWorks is an important issue for **ICT departments** because they can postpone new hardware installation due to the fact that SolidWorks carries relatively low hardware demands. The installation and management of SolidWorks on a network is very simple, particularly with a network licenses. And if a problem does arise, access to a qualified helpdesk will help you to get back on the right track.

Certification

When you have sufficiently learned SolidWorks, you can obtain certification by taking the Certified SolidWorks Associate (CSWA) exam. By passing this test, you will receive a certificate that attests to your proficiency with SolidWorks. This can be very useful when applying for a job or internship. After completing this series of tutorials for VMBO and MBO, you will know enough to take the CSWA exam.

Finally

SolidWorks has committed itself to serving the needs of educational institutions and schools both now and in the future. By supporting teachers, making tutorials available, updating the software annually to the latest commercial version, and by supplying the Student Kit, SolidWorks continues its commitment to serve the educational community. The choice of SolidWorks is an investment in the future of education and ensures ongoing support and a strong foundation for scholars and students who want to have the best opportunities after their technical training.

Contact

If you still have questions about SolidWorks, please contact your local reseller.

You will find more information about SolidWorks at our website: <http://www.solidworks.com>

SolidWorks Benelux
RTC Building
Jan Ligthartstraat 1
1800 GH Alkmaar, Netherlands
Tel: + 31 (0)72 514 3550